

OLYMPUS

DIGITAL CAMERA

Stylus 300/400 DIGITAL
μ [mjy:] 300/400 DIGITAL

REFERENCE MANUAL

CAMERA OPERATION MANUAL

Explanation of digital camera functions and operating instructions.

**DIGITAL CAMERA - PC CONNECTION
OPERATION MANUAL**

Explanation of how to download images between your digital camera and PC.

OLYMPUS

DIGITAL CAMERA

Stylus 300/400 DIGITAL *μ* [mju:] 300/400 DIGITAL

REFERENCE MANUAL

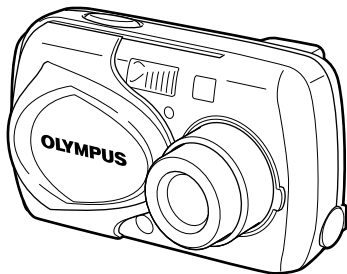

-
- Thank you for purchasing an Olympus digital camera. Before you start to use your new camera, please read these instructions carefully to enjoy optimum performance and a longer service life. Keep this manual in a safe place for future reference.
 - We recommend that you take test shots to get accustomed to your camera before taking important photographs.
 - This reference manual contains guidelines for using Olympus Stylus 300/400 DIGITAL (*μ* [mju:] 300/400 DIGITAL). Except where otherwise specified, the explanations in the manual apply to both models.
 - In the interest of continually improving products, Olympus reserves the right to update or modify information contained in this manual.

For customers in North and South America

For customers in USA

Declaration of Conformity

Model Number : Stylus 300 DIGITAL, Stylus 400 DIGITAL
RM-2 (Remote control)

Trade Name : OLYMPUS

Responsible Party : Olympus America Inc.

Address : 2 Corporate Center Drive, Melville, New York
11747-3157 U.S.A.

Telephone Number : 631-844-5000

Tested To Comply With FCC Standards
FOR HOME OR OFFICE USE

This device complies with Part 15 of the FCC rules. Operation is subject to the following two conditions:

- (1) This device may not cause harmful interference.
- (2) This device must accept any interference received, including interference that may cause undesired operation.

For customers in Canada

This Class B digital apparatus meets all requirements of the Canadian

For customers in Europe



“CE” mark indicates that this product complies with the European requirements for safety, health, environment and customer protection. “CE” mark cameras are intended for sales in Europe.

Trademarks



- IBM is a registered trademark of International Business Machines Corporation.
- Microsoft and Windows are registered trademarks of Microsoft Corporation.
- Macintosh is a trademark of Apple Computer Inc.
- All other company and product names are registered trademarks and/or trademarks of their respective owners.
- The standards for camera file systems referred to in this manual are the “Design Rule for Camera File System/DCF” standards stipulated by the Japan Electronics and Information Technology Industries Association (JEITA).

	Contents	P.4	
<p>Introduction of the camera's functions</p> <p>This section guides you through the basic operations from taking pictures to playing them back. "Quick-start guide" is designed for those who want to become familiar with the camera in a very short time.</p> <p>For fine-tuning the settings to get that particular shot</p> <p>For playing back and arranging pictures</p> <p>Settings that make the camera easier to operate.</p> <p>Printing pictures</p> <p>Troubleshooting and other information</p>	Getting started	P.8	1
	Quick-start guide	P.33	2
	Using the menus and tabs	P.39	3
	Shooting basics	P.47	4
	Advanced shooting	P.65	5
	Playback	P.83	6
	Useful functions	P.101	7
	Print settings	P.111	8
	Miscellaneous	P.117	9
	Specifications	P.133	
Glossary of terms	P.135		
index	P.137		



Contents

Contents	4
----------------	---

1 Getting started 8

Names of parts	8
Camera	8
Monitor indications	10
Weatherproof feature	14
How to use this manual	15
Attaching the strap	16
Charging the battery	17
Loading the battery	18
Using an optional AC adapter	20
Inserting a card	22
Card basics	22
Removing the card	24
Power on/off	25
If the card is not recognized (card check)	27
Selecting a language 	28
Setting the date and time 	30
Holding the camera	32



2 Quick-start guide 33

Shooting	33
Taking still pictures	33
Recording movies	34
Playback	35
Viewing still pictures	35
Viewing movies	36
Protecting pictures 	37
Erasing pictures (Single-frame erase) 	38







3 Using the menus and tabs 39

About the menus	39
How to use the menus	40
Shortcut menus	42
Mode Menus	44

4 Shooting basics 47









Shooting modes	47
Taking still pictures	50
Taking still pictures using the monitor	50
Taking still pictures using the viewfinder	51
Comparison of the viewfinder & monitor	53
If correct focus cannot be obtained	54
Determine the position of the subject after focusing (Focus Lock)	54
Subjects that are difficult to focus on	55
Night scene mode 	56
Recording movies 	57
Zoom	59
Using the optical zoom	59
Using the digital zoom	60
Using the flash 	62

5 Advanced shooting 65



Macro mode shooting 	65
Self-timer shooting 	66
Remote control shooting 	67
Selecting the metering area ESP , 	69
Sequential shooting  , 	70
Panorama shooting	71
Taking two-in-one pictures 2 IN 1	73
Selecting a record mode 	75

Varying the image brightness (Exposure compensation) 	79
Adjusting the White balance WB	81





6 Playback 83

Viewing still pictures 	83
QUICK VIEW	84
Close-up playback 	85
Index display 	86
Selecting the number of pictures	87
Slideshow 	88
Playback on a TV	89
Picture Rotation 	90
Viewing movies 	91
Protecting pictures 	93
Erasing pictures 	94
Single-frame erase	94
All-frame erase	95
Editing still pictures	96
Creating black and white pictures	96
Creating sepia-toned pictures	97
Resizing pictures 	97
Creating an index	99

7 Useful functions 101

Saving the settings (All Reset)	101
Formatting cards (Card setup) 	103
Displaying shooting information INFO	105
Adjusting the monitor brightness 	106
Viewing a picture immediately after shooting (Rec View)	107
Turning the beep sound off 	108
Pixel Mapping	109
Video output selection	110

8 Print settings 111

How to print pictures 	111
All-frame reservation  ^{ALL}	113
Single-frame reservation 	114
Resetting print reservation data 	116

9 Miscellaneous 117

Error codes	117
Troubleshooting	119
Menu List	124
Factory default settings	128
List of functions by shooting mode	130
Camera maintenance	131
Specifications	133
Glossary of terms	135
index	137

1 Getting started

Names of parts

Camera

1

Getting started

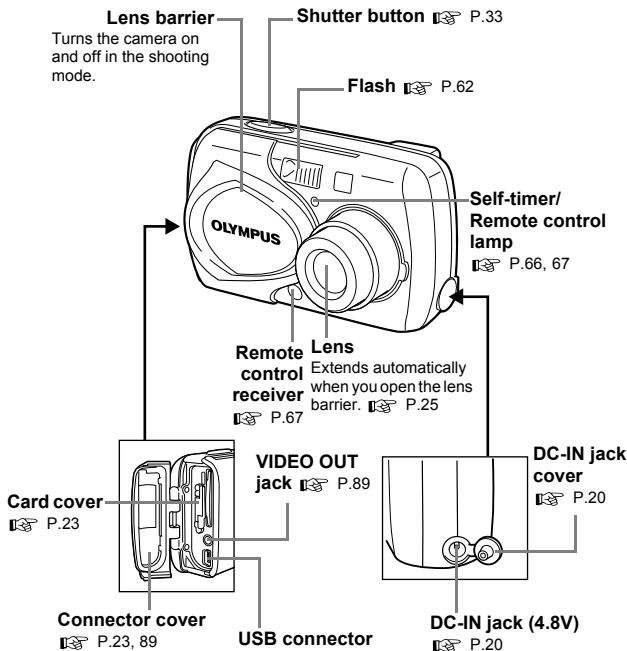

Arrow pad

The arrow pad is used as arrow keys, as well as function buttons. The \triangle , ∇ , \triangleleft , and \triangleright marks indicate which arrow key to press.

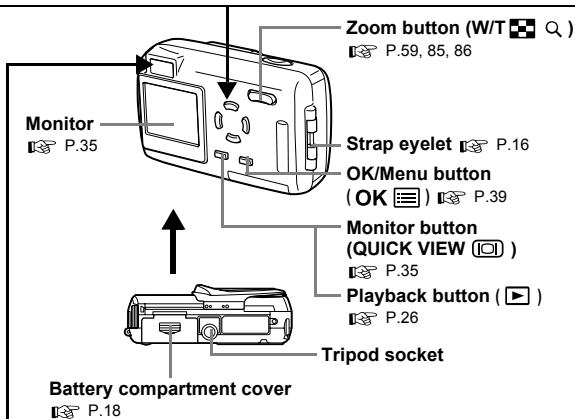
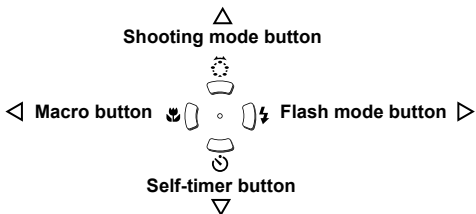
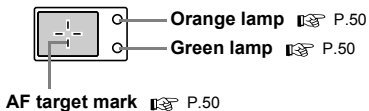
**Viewfinder**

Monitor indications

● Shooting mode

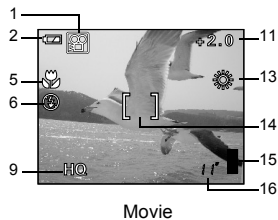
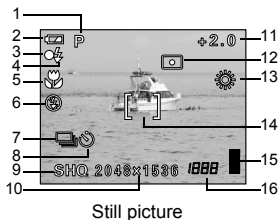

	Items	Indications	Ref. page
1	Shooting mode	P , , , , , , , ,	P.47
2	Battery check	,	P.13
3	Green lamp		P.50
4	Flash stand-by/ Camera movement warning/ Flash charge	(Lights) (Blinks)	P.62
5	Macro mode		P.65
6	Flash mode	, ,	P.62
7	Sequential shooting	,	P.70
8	Self-timer Remote control	 	P.66 P.67
9	Record mode	SHQ, HQ, SQ1, SQ2	P.75
10	Resolution	2272 × 1704, 2048 × 1536, etc.	P.76
11	Exposure compensation	-2.0 – +2.0	P.79
12	Metering		P.69
13	White balance	, , ,	P.81
14	AF target mark	[]	P.54
15	Memory gauge	, , ,	P.13

	Items	Indications	Ref. page
16	Number of storable still pictures	16	P.50
	Seconds remaining	16"	P.57

●Playback mode

INFO setting allows you to select how much information to display on the monitor. Screens when the Information display is set to ON are shown below.



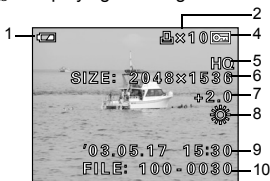





 "Displaying shooting information" (P.105)



Still picture



Movie

	Items	Indications	Ref. page
1	Battery check	 , 	P.13
2	Print reservation, Number of prints	 ×10	P.111
3	Movie		P.91
4	Protect		P.93
5	Record mode	SHQ, HQ, SQ1, SQ2	P.75
6	Resolution	2272 × 1704, 2048 × 1536, etc.	P.76
7	Exposure compensation	-2.0 – +2.0	P.79
8	White balance	AUTO,  ,  ,  , 	P.81
9	Date and time	'03.05.17 15:30	P.30
10	File number (still picture) Playing time/Total recording time (movie)	FILE: 100-0030 0"/20"	—



Note

- The indications that appear on a movie picture that has been selected and displayed from the index display are different from those that appear when the movie picture is displayed using the movie playback function.

●Memory gauge

The memory gauge lights up when you take a picture or record a movie. While the gauge is lit, the camera is storing the picture or the movie on the card. The memory gauge indication changes as shown below depending on the shooting status.

When the whole memory gauge is lit, wait a few moments until the lit area goes off before taking the next shot.

When taking still pictures

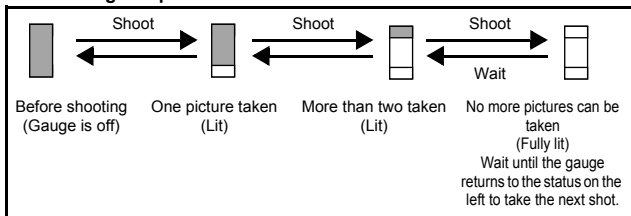

When recording movies

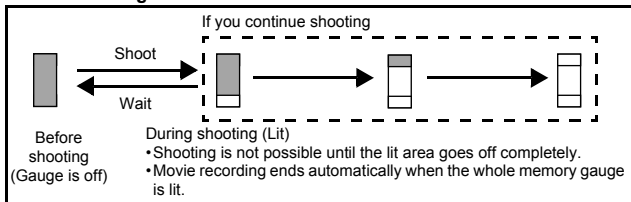

●Battery check

If the remaining battery power is low, the battery check indication on the monitor changes as follows when the camera is turned on or while the camera is in use.

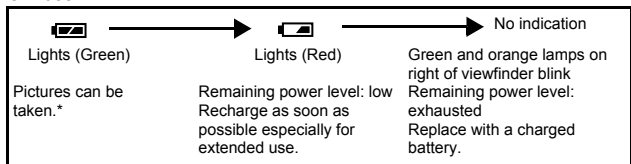

* Energy consumption varies greatly depending on the camera's operational status. The camera may turn off without displaying the low battery warning. Recharge as soon as possible.

Weatherproof feature

1

Getting started

The camera is weatherproof and is not damaged by water spray from any direction. However, it cannot be used underwater. Observe the following precautions when using the camera.

Olympus will not assume any responsibility for malfunction of the camera caused by water getting inside as a result of misuse by the user.



• Do not wash the camera with water.

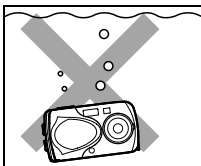

• Do not drop the camera into water.



• Do not take pictures underwater.

- The camera loses its waterproof capability if the battery compartment cover, connector cover or DC-IN jack cover is open. Make sure that all the covers are closed before using the camera.
- Wipe any water off the camera before changing the battery or card.
- Keep the lens out of the water when taking pictures. (The camera may not focus correctly.)
- If the camera gets splashed, wipe the water off as soon as possible with a dry cloth. Salt water spray or droplets can cause damage to the camera if the camera is not wiped dry as soon as possible.
- Do not apply excessive force to or attempt to peel off the rubber packing of the battery compartment cover, connector cover or DC-IN jack cover.
- If the rubber packing becomes worn or damaged, contact your nearest Olympus service center. (A charge is made for replacement of parts.)
- If the rubber packing of the battery compartment cover, connector cover or DC-IN jack cover contains dirt or sand, wipe it off before closing the cover, otherwise water may get inside the camera.
- The rechargeable battery and other camera accessories are not weatherproof. Care should be taken when using the accessories.



How to use this manual



Follow the arrows to perform menu operations. For details of operating procedures, see "How to use the menus" (P.40).

Adjusting the monitor brightness 



This function lets you adjust the brightness of the monitor. The brightness can be adjusted in either the shooting mode or the playback mode.



1 In the top menu, select **MODE MENU** → **SETUP** → , and press **▷**.
☞ "How to use the menus" (P.40)

2 Press  to adjust the brightness of the monitor, and when you have set the desired level, press **OK** .





- Pressing  brightens the monitor, and pressing  darkens it.

The buttons for the function and their location are clearly illustrated.

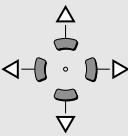



, ,  and  indicate which button to press on the arrow pad.

1

Getting started

This sample page is only for your reference. It may differ from the actual page in this manual.

Indications used in this manual

 Note	Important information on factors which may lead to a malfunction or operational problems. Also warns of operations that should be absolutely avoided.
	Useful information and hints that will help you get the most out of your camera.
	Reference pages describing details or associated information.

Attaching the strap

- 1 Thread the short end of the strap through the strap eyelet.
- 2 Thread the long end of the strap through the loop that has already gone through the eyelet.
- 3 Pull the strap tight, making sure that it is securely fastened and does not come loose.

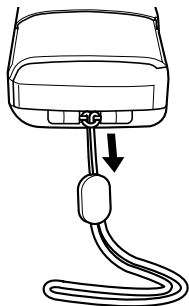
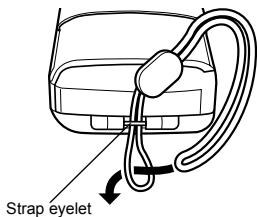

1 Getting started



Note

- Do not pull the strap too hard as this may cause it to break.
- Be careful with the strap when you carry the camera, as it can easily catch on stray objects, causing injury or damage.
- Attach the strap correctly following the procedure so that the camera does not fall off. If the strap is attached incorrectly and the camera falls off, Olympus is not responsible for any damages.

Charging the battery

This camera uses an Olympus lithium ion battery (LI-10B). The battery is dedicated to this camera and other batteries do not work. The battery is not fully charged when the camera is purchased. Fully charge the battery on the specified charger (LI-10C) before first use. For details, read the charger's instructions (provided).

●About the battery

Make sure that the + and – terminals of the battery shown in the illustration on the right are correctly oriented when loading the battery into the charger.

Charge indicator
When charge indicator changes from red to green, the battery is fully charged.

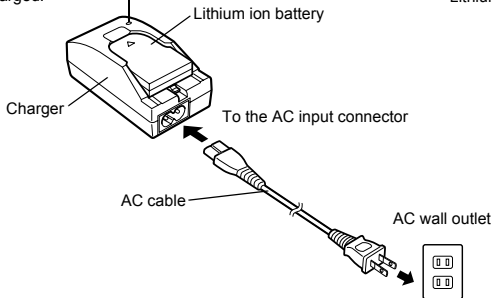

Connector terminals

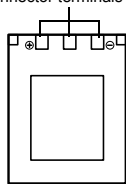

Lithium ion battery

1

Getting started



- Use only the specified charger.
- We recommend that you keep a spare battery (sold separately) with you if you are planning to use the camera for long periods.

Loading the battery

Use an Olympus LI-10B lithium ion battery.

Important

- Be sure to check the date and time after changing the battery.

1 Make sure that:

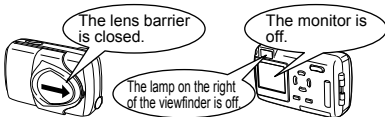

- ### 2 Slide the battery compartment cover in the direction of (A) (the direction indicated by the mark on the cover), and lift it up in the direction of (B).

Battery compartment cover

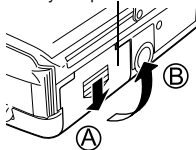

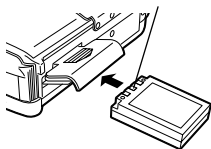

- ### 3 Insert the battery in the direction shown in the illustration.

Connector terminals

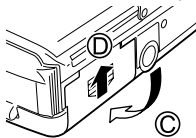

- ### 4 Close the battery compartment cover so that it pushes the battery down inside (C). While pressing the mark, slide the cover in the direction of (D).



- If the battery compartment cover seems hard to close, do not force it. With the battery compartment cover shut, press the  mark firmly and push in the direction shown in the illustration.



Note

- If the camera is left for about a day with the battery removed, the date and time settings will revert to the factory default settings.

Precautions when using the battery

The amount of power consumed varies considerably depending on the operations performed on the digital camera. If you use an exhausted battery, the camera may turn off without displaying the battery level warning (P.13).

●Removing the battery**1 Turn the camera over so that it is upside down.**

- This will prevent the battery from falling out when you open the battery compartment cover.

2 Slide the battery compartment cover in the direction of (A) (the direction indicated by the  mark on the cover), and lift it up in the direction of (B).

Battery compartment cover

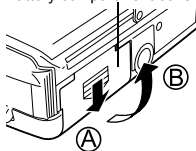
**3 Remove the battery.**

- Keeping your hand over the battery compartment, return the camera to the upright position to remove the battery.

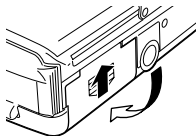
**4 Close the battery compartment cover.**

Note

- Be sure to turn the camera upside down before opening the battery compartment cover to prevent the battery from falling out.

Using an optional AC adapter

In addition to the lithium ion battery provided with the camera, you can also use an AC adapter. Choose the power source best suited to the situation. An optional Olympus AC adapter allows you to power your digital camera from a common AC wall outlet. Be sure to use the specified AC adapter. An AC adapter is useful for time-consuming tasks such as image downloads. Use an AC adapter designed to operate on the AC voltage in the area the camera is being used. Consult your nearest Olympus dealer or Service center for details.

1 Getting started

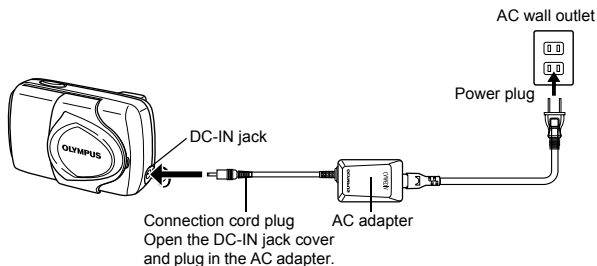

Note

- If the battery power runs out while the camera is connected to a PC, the image data may be lost or damaged. You are recommended to use the AC adapter when transferring images to a PC. Do not connect or disconnect the AC adapter while the camera is communicating with the PC.
- Do not remove or load the batteries or connect or disconnect the AC adapter while the camera is turned on. Doing so could affect the camera's internal settings or functions.

- Power is consumed continuously during the conditions described below. This could mean that the battery runs down faster.
 - When the monitor is in the playback mode for an extended period of time.
 - Repeated zoom adjustments.
 - Repeated auto-focus by depressing the shutter button halfway.
 - When the camera is connected to a PC.
- Carefully read the separate-volume Safety Precaution before use.
- When using an AC adapter, power is supplied to the camera by the AC adapter even if batteries are loaded in the camera. The AC adapter does not charge batteries in the camera.

Inserting a card

"Card" in this manual refers to the xD-Picture Card. The camera uses the card to record pictures.

Card basics

The card corresponds to normal camera film for recording the pictures you have taken. Pictures recorded and stored on the card can easily be erased, overwritten, and/or edited on a PC.

1
Getting started

- ① Index area
You can write down the card's contents.
- ② Contact area
Comes into contact with the camera's signal read contacts.

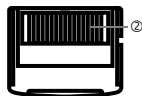

Compatible cards

- xD-Picture Card (16 to 256 MB)



Note

- This camera may not recognize a non-Olympus card or a card that was formatted on another device (such as a PC, etc.). Before use, be sure to format the card on this camera. ➔ "Formatting cards (Card setup)" (P.103)

1 Make sure that:

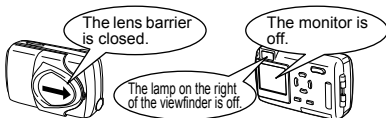

- ## 2 Open the connector cover while pressing the (A) mark in the illustration.

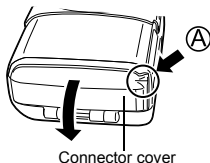

- 3** Open the card cover by pulling the card cover catch towards you.

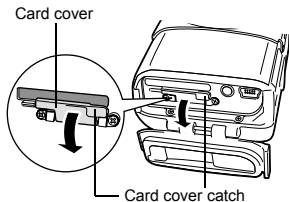

- 4** Face the card the correct way and insert it into the card slot.

- Insert the card while keeping it straight.
- Inserting the card the wrong way or at an angle could damage the contact area or cause the card to jam.
- If the card is not inserted all the way, data may not be written to the card.

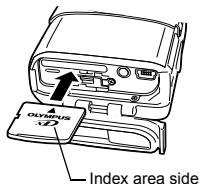

- 5** Close the card cover.

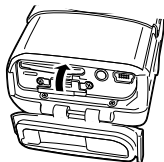

- 6** Close the connector cover.

- Press the (A) mark in the illustration when closing the connector cover.

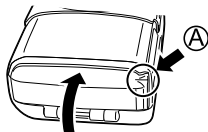

Note

Do not close the connector cover without first closing the card cover.

Removing the card

- 1 Open the connector cover and the card cover.
- 2 Push the card all the way in to unlock it, then let it return slowly.
 - The card is ejected a short way and then stops.

Note

Releasing your finger quickly after pushing the card all the way in may cause it to eject forcefully out of the slot.

- 3 Hold the card straight and pull it out.

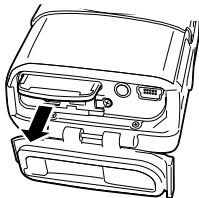
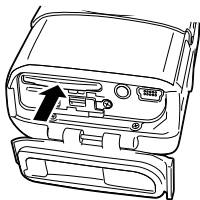

Note

- Do not press on the card with hard or pointed items such as ballpoint pens.
- Never open the card cover, or remove the card or the battery while the camera is turned on. Doing so could destroy the data on the card. Once destroyed, data cannot be restored.
- Do not push the card in when the card cover is closed. Doing so could damage the card or the camera.



Power on/off

●When shooting pictures

Power on: **Open the lens barrier.**

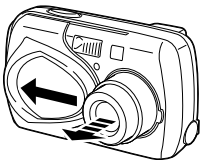
The camera turns on in the shooting mode. The lens extends and the subject is displayed on the monitor. If the lens does not extend when the lens barrier is opened, there is a possibility that the barrier is not fully open. Open the lens barrier fully until you feel it click.



When using the camera for the first time or after the camera has been left for about a day with the battery removed, the date and time are reset. In this event, "SET DATE & TIME" appears on the monitor when the camera is turned on.  "Setting the date and time" (P.30) Press  to turn off the monitor. The camera is still on.

Power off: **Close the lens barrier slightly until it almost touches the lens barrel.**

The lens barrier stops just before it touches the lens and the lens retracts. Wait until the lens is fully retracted before closing the lens barrier completely. The camera turns off. (The monitor also turns off.)

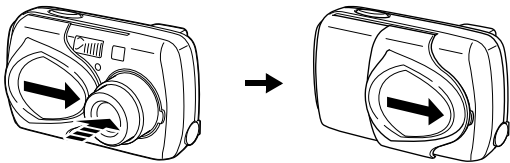

TIPS



- To save battery power, the camera automatically enters the sleep mode and stops the operation after about 3 minutes of non-operation. If the monitor is on, it will automatically turn off. The lens retracts automatically 5 minutes after that. The camera activates again as soon as you lightly press the shutter button or zoom button. Whenever possible, turn the camera off when you do not intend to take any pictures for a while.



Note

- Do not push the lens barrier forcefully against the lens as this may damage the lens or cause it to malfunction.

1

Getting started

●When playing back pictures**1**
Getting started

Power on: Press  with the lens barrier closed.
The camera turns on in the playback mode. The monitor turns on and the last picture taken is displayed.

Power off: Press  .
The monitor and the camera turn off.

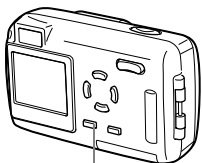
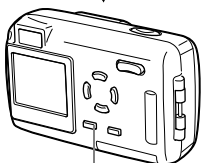
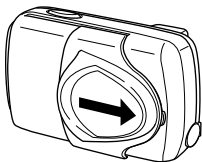
**TIPS**

- When the camera turns on, the monitor may light up for an instant and a picture appear after a short time. This is not a malfunction.



Note

- Never open the card cover, remove the card or the battery, or connect or disconnect the AC adapter while the camera is turned on. Doing so could destroy all data on the card. Destroyed data cannot be restored. When changing the card, be sure to turn the camera off before opening the card cover.

If the card is not recognized (card check)

When the power is turned on, the camera checks the card automatically. If there is no card in the camera or a card that is not supported by this camera is inserted, the following screen is displayed.







Note

- All data stored on the card is erased when the card is formatted.

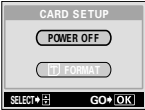
1

Getting started

Monitor indication	Corrective action
 NO CARD	<p>There is no card in the camera or the card is not inserted properly.</p> <p>→ Insert a card. If a card is already inserted, remove it and insert it again correctly.</p>
	<p>The card cannot record, play back or erase pictures. Replace it with a new one or format the card.</p> <p>→ Press Δ ∇ to select POWER OFF, then press OK . Replace it with a new one.</p> <p>→ Format the card.</p> <p>Press Δ ∇ to select FORMAT , then press OK  to display the confirmation screen. Select YES and press OK .</p> <p>Formatting starts. If the card was successfully formatted, the camera is ready to take pictures.</p>

Selecting a language



You can select a language for on-screen display. This reference manual shows the English on-screen display in the illustrations and explanations. Available languages vary depending on the area where you purchased this camera.

1

Getting started

- 1 Open the lens barrier fully.**
 - The lens extends and the monitor turns on.
- 2 Press OK .**
 - The top menu is displayed.

Arrow pad (   )

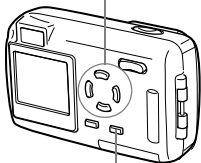

OK 

- 3 Press  on the arrow pad to select MODE MENU.**

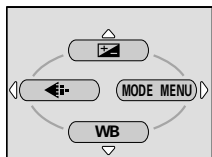



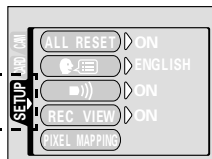

Top menu

- 4 Press   to select the SETUP tab, then press .**

SETUP tab 



- 5 Press   to select  , then press .**

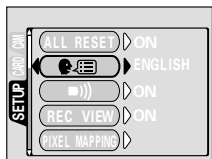

- 6 Press Δ ∇ to select a language, then press OK \equiv .
- 7 Press OK \equiv again to exit the menu.
- 8 Close the lens barrier to turn the camera off.

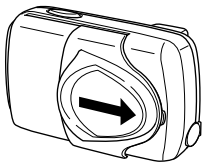
**TIPS**

- The language can also be set from the playback mode.

Setting the date and time



- 1 Open the lens barrier fully.**
 - The lens extends and the monitor turns on.
- 2 Press OK .**
 - The top menu is displayed.

Arrow pad (   )

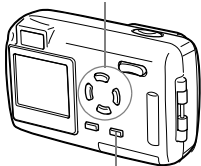

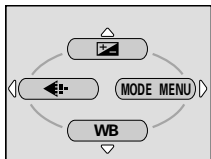

OK 

- 3 Press  on the arrow pad to select MODE MENU.**





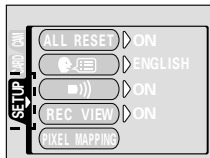

Top menu

- 4 Press   to select the SETUP tab, then press .**

SETUP tab 



- 5 Press   to select , then press .**
 - The green frame moves to the selected item.
 - The camera only displays the time in 24-hour time system ("2 p.m" would be "14:00").

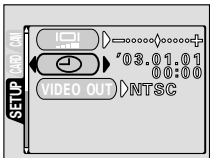

1

Getting started

- 6** Press Δ ∇ to select one of the following date formats: Y-M-D (Year/Month/Day), M-D-Y (Month/Day/Year), D-M-Y (Day/Month/Year). Then press \triangleright .

- Move to the year setting.
- The following steps show the procedure used when the date and time settings are set to Y-M-D.

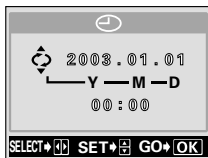

- 7** Press Δ ∇ to set the year, then press \triangleright to move to the month setting.

- To move back to the previous setting, press \triangleleft .
- The first two digits of the year are fixed.

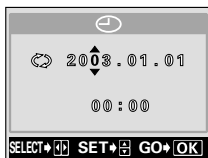

- 8** Repeat this procedure until the date and time are completely set.

- The camera only displays the time in 24-hour time system ("2 p.m" would be "14:00").

- 9** Press **OK** $\left[\text{Menu} \right]$.

- For a more accurate setting, press **OK** $\left[\text{Menu} \right]$ when the time hits 00 seconds. The clock starts when you press the button.

- 10** Close the lens barrier to turn the camera off.

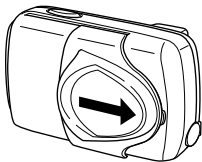

Note

- The current settings are retained even when the power is turned off, unless they are readjusted.
 - The date and time settings will be canceled if the camera is left without the battery for approximately one day. The settings will be canceled more quickly if the battery was only loaded in the camera for a short time before being removed. Before taking important pictures, check that the date and time settings are correct.
 - If the date and time setting has been canceled, a warning will be displayed on the monitor next time the camera is turned on.
- $\left[\text{Info} \right]$ "Error codes" (P.117)

**TIPS**

- The date and time can also be set from the playback mode.

Holding the camera

When taking pictures, hold the camera firmly with both hands while keeping your elbows at your sides to prevent the camera from moving. When taking pictures in the vertical position, hold the camera so that the flash is at the top.

Taking pictures using the monitor

1

Getting started



Taking pictures using the viewfinder

Horizontal grip

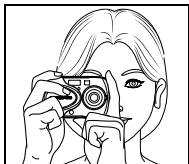

Vertical grip



Incorrect grip

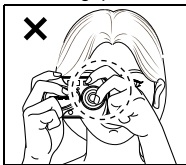

Keep your fingers and the strap away from the lens and flash.



Note

- Clear pictures cannot be obtained if the camera moves as the shutter button is pressed. Hold the camera correctly, and press the shutter button gently.

2 Quick-start guide

Shooting

Taking still pictures

P.50

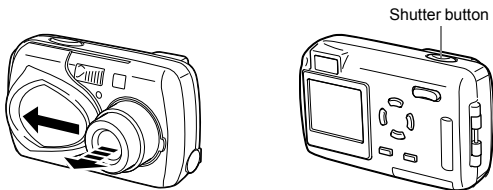

- 1 Open the lens barrier fully.**
- 2 Decide the composition of the picture while looking at the image on the monitor.**

3 Press the shutter button.

- When the flash is required, the orange lamp lights and the flash fires automatically.
- The orange lamp blinks while the picture is stored on the card.



TIPS

To change the shooting mode

When you want to take a portrait or landscape etc.

"Shooting modes" (P.47)

When the subject is difficult to focus on

"If correct focus cannot be obtained" (P.54)

To take a subject that is less than 50 cm (1.6 ft.) away

"Macro mode shooting" (P.65)

To take a picture using the viewfinder

"Taking still pictures using the viewfinder" (P.51)

Recording movies

P.57

2

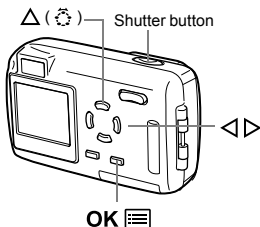
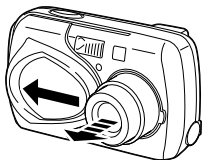

Quick-start guide



1 Open the lens barrier fully.

2 Press Δ ().

- The virtual dial screen (Shooting mode selection screen) is displayed.

3 Press $\triangleleft \triangleright$ to select , then press OK .

4 Decide the composition while looking at the image on the monitor and press the shutter button halfway.

- The focus and white balance are locked.

5 Press the shutter button fully to start recording.

- During movie recording,  lights red on the monitor.

6 Press the shutter button again to stop recording.

- The orange lamp blinks while the movie is stored on the card.

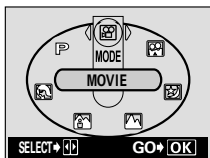

Virtual dial screen



TIPS

For details of movie recording
 "Recording movies" (P.57)

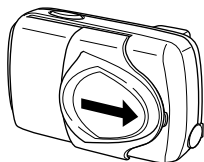

Arrow pad (Δ ∇ \triangleleft \triangleright)

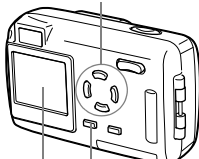

1 Press with the lens barrier closed.

- The monitor turns on and displays the last picture taken.



2 Use the arrow pad to play back other pictures.

Jumps to the picture 10 frames back.

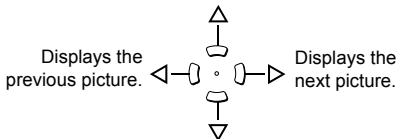

Jumps to the picture 10 frames ahead.



TIPS

To enlarge the picture on the monitor

☞ "Close-up playback" (P.85)

To display several pictures at once

☞ "Index display" (P.86)

To view pictures on a TV

☞ "Playback on a TV" (P.89)

Viewing movies

2

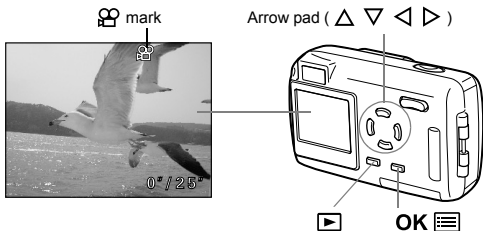

1 Press with the lens barrier closed.

2 Use the arrow pad to display the picture with , then press **OK** .

- The top menu is displayed.

3 Press to select **MOVIE PLAY**.



4 Press to select **MOVIE PLAYBACK**, then press **OK** .

- The movie is played back.
- When playback ends, the display automatically returns to the beginning of the movie.
- Press **OK** again after playback ends to display the **MOVIE PLAYBACK** menu.

PLAYBACK : Plays back the entire movie again.

FRAME BY FRAME

: Plays back the movie manually one frame at a time.

EXIT : Leaves the movie playback mode.



Press to select from **PLAYBACK**, **FRAME BY FRAME** or **EXIT**, then press **OK** .

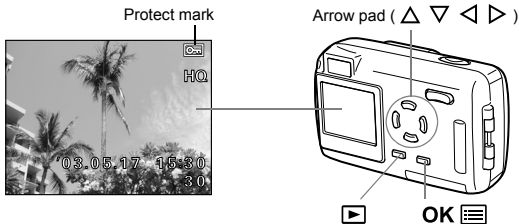

1 Press with the lens barrier closed.

- The monitor turns on.

2 Use the arrow pad to display the picture you want to protect, then press .

- The top menu is displayed.

3 Press in the top menu to display the MODE MENU.

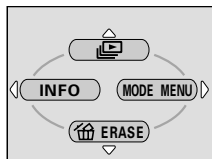

4 Press to select PLAY, then press .

5 Press to select , then press .

6 Press to select ON, then press .

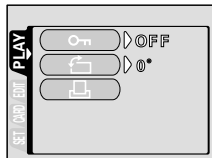

7 Press to exit the menu.

- The Protect icon appears on the screen.



TIPS





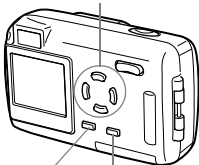

For details of the mode menu

"About the menus" (P.39)

To cancel protection

"Protecting pictures" (P.93)

Arrow pad (   )OK 

- 1 Press  with the lens barrier closed.
- 2 Use the arrow pad to display the picture you want to erase, then press OK  .
 - The top menu is displayed.
- 3 Press  in the top menu to select  .
- 4 Press   to select YES, then press OK  .
 - The picture is erased.

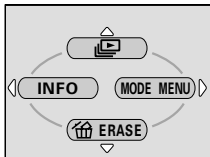

TIPS

For details of the top menu

 "About the menus" (P.39)

To erase all the pictures

 "All-frame erase" (P.95)

3 Using the menus and tabs

About the menus

When you turn on the camera and press **OK** , the top menu is displayed on the monitor. The functions of this camera are set from the menu. This chapter explains how the menus work, using the shooting mode screens.

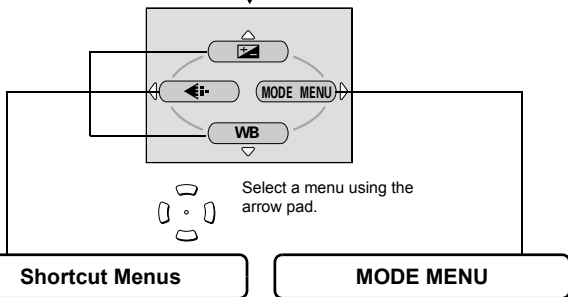
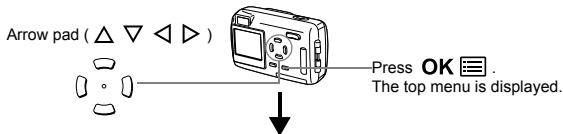

- Shortcut Menu**
- Take you directly to the setting screens.
 - Display operational buttons at the bottom of the screen.

- MODE MENU**
- Categorizes the settings into tabs.
 - Displays the tabs of each menu. Select the desired tab on the left of the screen by pressing Δ ∇ .

If you press Δ to select .

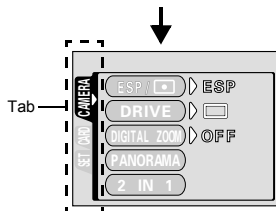
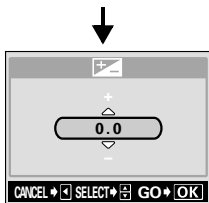

How to use the menus

1 Press **OK**  to display the top menu. Press **▷**.

2 Press **△** **▽** to select a tab, then press **▷**.

Top menu

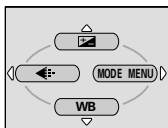

CAMERA tab

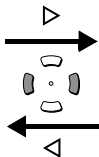
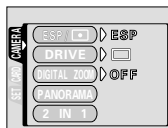

Press **△** to return to the tab selection screen.

CARD tab

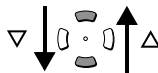
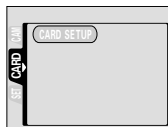

SETUP tab

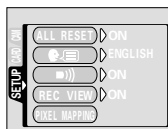

3

Using the menus and tabs

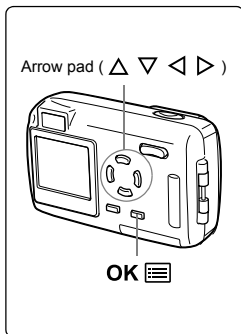

- 3 Press Δ ∇ to select an item, then press \triangleright .

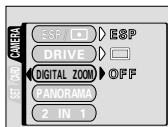
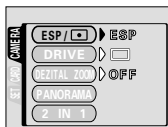

The green frame moves to the selected item.

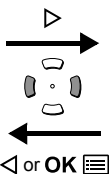

To return to select an item, press \triangleleft or **OK** [Menu icon].

- 4 Press Δ ∇ to select a setting. Press **OK** [Menu icon] to complete setting. Press **OK** [Menu icon] again to exit the menu and return to shooting.

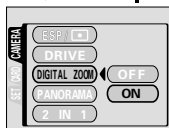
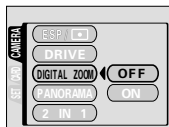

Note

- Not all items can be selected depending on the camera mode and settings.
- Pressing the shutter button with a menu other than the menus in SETUP tab open allows you to take pictures using the settings currently selected.
- If you want to save the settings after the camera is turned off, set ALL RESET to OFF. "Saving the settings (All Reset)" (P.101)

Shortcut menus

● Shooting mode

Shortcut menus are frequently used menus that can be accessed from the top menu.

Still picture/Movie

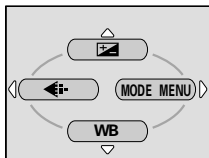

3

Using the menus and tabs



Adjusts the brightness of the picture.

P.79



Sets the image quality and resolution.

Still picture : SHQ, HQ, SQ1, SQ2

Movie : HQ, SQ

P.75

WB

Sets the appropriate white balance according to the light source.

P.81

● Playback mode

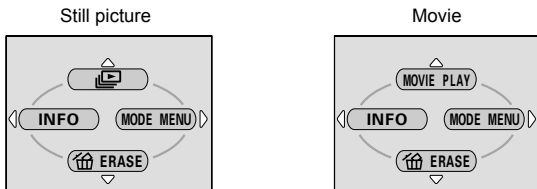

Runs through all saved pictures one after another as slide show.

P.88

MOVIE PLAY

MOVIE
PLAYBACK

Plays back movies.

P.91

INDEX

Creates an index picture of a movie in 9 frames.

P.99

INFO

Displays all the shooting information on the monitor.

P.105



ERASE

Erases the selected still picture or movie.

P.94

Mode Menu

The MODE MENU is divided into tabs. Press Δ ∇ to select a tab and display the associated menu items.

● Shooting mode

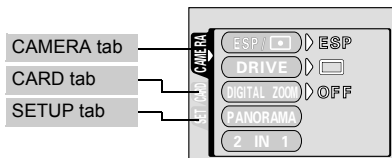



3

Using the menus and tabs

CAMERA tab		
ESP/	Selects the metering method from ESP or SPOT ().	P.69
DRIVE	Selects the shooting mode from (single-frame shooting) or (sequential shooting).	P.70
DIGITAL ZOOM	Extends the maximum optical zoom, making possible up to approx. 5x zoom.	P.60
PANORAMA	Allows panorama pictures to be taken with Olympus CAMEDIA-brand cards.	P.71
2 IN 1	Combines two still pictures taken in succession and stores them as a single picture.	P.73



CARD tab		
CARD SETUP	Formats a card.	P.103

SETUP tab		
ALL RESET	Selects whether to keep the current camera settings when you turn off the power.	P.101
	Selects a language for on-screen display.	P.28
	Turns the beep sound (used for warnings, etc.) on and off.	P.108
REC VIEW	Selects whether to display pictures on the monitor while saving them to a card.	P.107

PIXEL MAPPING	Checks the CCD and image processing functions for errors.	P.109
	Adjusts the brightness of the monitor.	P.106
	Sets the date and time.	P.30
VIDEO OUT	Selects NTSC or PAL according to your TV's video signal type. TV video signal types differ depending on the region.	P.110

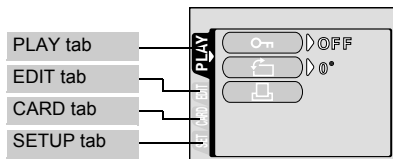



● Playback mode



PLAY tab		
	Protects pictures from accidental erasure.	P.93
	Rotates pictures 90 degrees clockwise or counterclockwise.	P.90
	Stores print reservation information on the card.	P.111

EDIT tab		
BLACK&WHITE	Creates a black and white picture and saves it as a new picture.	P.96
SEPIA	Creates a sepia-toned picture and saves it as a new picture.	P.97
	Makes the file size smaller and saves it as a new picture.	P.97

CARD tab		
CARD SETUP	Erases all image data stored on the card or formats the card.	P.95 P.103

SETUP tab		
ALL RESET	Selects whether to keep the current camera settings when you turn off the power.	P.101
	Selects a language for on-screen display.	P.28
	Turns the beep sound (used for warnings, etc.) on and off.	P.108
	Adjusts the brightness of the monitor.	P.106
	Sets the date and time.	P.30
VIDEO OUT	Selects NTSC or PAL according to your TV's video signal type. TV video signal types differ depending on the region.	P.110
	Selects the number of frames in the index display.	P.87

4 Shooting basics

Shooting modes

This camera has 7 shooting modes to choose from depending on the shooting conditions and the effect you want to achieve.

1 Open the lens barrier fully.

- The lens extends and the monitor turns on.

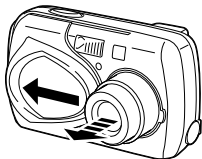

2 Press Δ ().

- The screen for selecting the shooting mode (virtual dial) is displayed.

Arrow pad (Δ ∇ \triangleleft \triangleright)

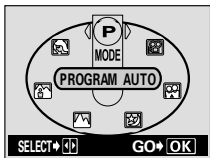
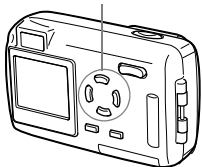

Virtual dial screen

3 Select the mode best suited to your purpose from the following.

- Press \triangleleft \triangleright to select the mode.

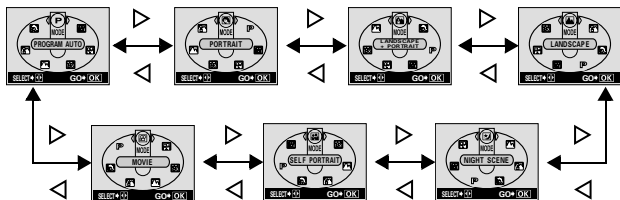

4 Press OK \equiv .

- The virtual dial screen will disappear. It will disappear after a while even if the **OK** \equiv button is not pressed.

4

● **P PROGRAM AUTO (Factory default setting)**

Used for regular photography. The camera automatically makes the settings for natural color balance. Other functions, such as the flash mode and metering, can be adjusted manually.

● **👤 PORTRAIT**

Suitable for taking a portrait-style shot of a person. Importance is placed on reproducing skin texture. The camera automatically sets the optimal shooting conditions.

● **🏞️ LANDSCAPE + PORTRAIT**

Suitable for taking photos of both your subject and the landscape. The camera automatically sets the optimal shooting conditions.

● **🏞️ LANDSCAPE**

Suitable for taking photos of landscapes and other outdoor scenes. The camera automatically sets the optimal shooting conditions.

● NIGHT SCENE

Suitable for shooting pictures in the evening or at night. The camera sets a slower shutter speed than is used in normal shooting. If you take a picture of a street at night in any other mode, the lack of brightness will result in a dark picture with only dots of light showing. In this mode, the true appearance of the street is captured. The camera automatically sets the optimal shooting conditions.  “Night scene mode” (P.56)





● SELF PORTRAIT

Enables you to take a picture of yourself while holding the camera. Point the lens towards yourself and the focus will be locked on you. The camera automatically sets the optimal shooting conditions. The zoom is fixed in the Wide position and cannot be changed.



● MOVIE

Lets you record movies. The camera maintains the correct exposure even if your subject moves. You cannot record movies with sound.  “Recording movies” (P.57)

 **TIPS**
 Refer to “List of functions by shooting mode ( P.130) for details of the functions for each mode.

 • The spot metering and digital zoom are not available in Self-Portrait mode.

Note

Taking still pictures

You can take still pictures using either the monitor or the viewfinder. Both methods are easy as all you have to do is to press the shutter button.

Taking still pictures using the monitor

With the monitor, you can shoot while checking the picture area that the camera actually records.

1 Open the lens barrier fully.

- Slide the lens barrier fully open until it clicks.
- The lens extends and the monitor turns on.

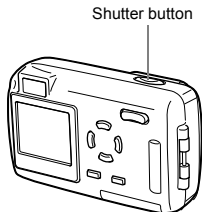

4

Shooting basics

2 Position the AF target mark on the subject while looking at the image on the monitor. Decide the composition of the picture.

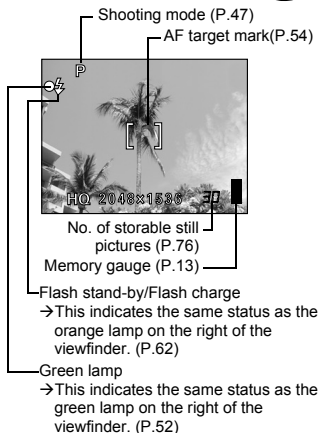

3 Press the shutter button gently (halfway) to adjust the focus.

- When the focus and exposure are locked, the green lamp lights.
- If the orange lamp lights, the flash fires automatically.



4 Press the shutter button all the way (fully).

- The camera takes the picture, and a beep sounds.
- When the green lamp stops blinking, you can take the next picture.
- The orange lamp blinks while the picture is stored on the card.

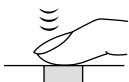

TIPS

The monitor turns off automatically.

→ If the camera is not used for over 3 minutes, the monitor turns off automatically. The lens retracts 5 minutes after that. Touch the shutter button or zoom button to turn the monitor on again.

The monitor is hard to see.

→ Bright light, such as direct sunlight, may cause vertical lines to appear on the monitor screen. In this case, use the viewfinder.

Taking still pictures using the viewfinder

The camera captures a slightly larger image than what is seen through the viewfinder.

1 Open the lens barrier fully.

- The lens extends and the monitor turns on.
- Press  to turn the monitor off.

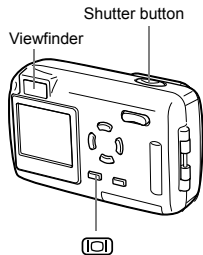

2 Position the AF target mark in the viewfinder on the subject.

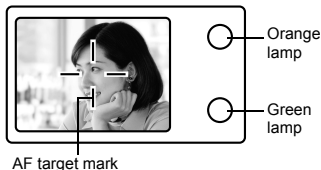

3 Take the picture by following the same procedure as for shooting using the monitor.

☞ “Taking still pictures using the monitor” (P.50)



TIPS

The green lamp blinks.

→ You are too close to the subject. Take the picture at least 50 cm/1.6 ft. away from the subject. When the distance from the camera to the subject is less than 50 cm/1.6 ft, select the macro mode.

☞ “Macro mode shooting” (P.65)

→ Depending on the subject, the focus may not be locked.

☞ “Subjects that are difficult to focus on” (P.55)

The orange lamp blinks slowly when the shutter button is pressed halfway.

→ The flash is charging. When the orange lamp blinks quickly after shooting, the picture you just took is being stored. Wait until the lamp goes off.

To check the picture you have just taken immediately.

→ Set REC VIEW to ON. ☞ “Viewing a picture immediately after shooting (Rec View)” (P.107)



Note

- Press the shutter button gently using the ball of your finger. If it is pressed hard, the camera may move and pictures may come out blurred.
- Recorded pictures will be saved on the card regardless of whether the camera is turned off or the battery is changed or removed.

- Never open the card cover, remove the battery or disconnect the AC adapter while the orange lamp is blinking. Doing so could destroy stored pictures and prevent storage of the pictures you have just taken.
- When taking pictures against strong backlight, the area of the picture in shadow may appear colored.
- When you point the camera lens toward a bright subject, smears (lines like beams of light) may appear on the image in the monitor. This does not affect recorded pictures.

Comparison of the viewfinder & monitor

	Viewfinder	Monitor
Advantages	Camera movement does not occur easily and subjects can be seen clearly even in bright places. Little battery power is used.	You can check the picture area that the camera actually records more accurately.
Disadvantages	When close to a subject, the image in the viewfinder is a little different from the picture that the camera actually records.	Camera movement can occur easily and subjects may be difficult to see in bright/dark places. The monitor uses more battery power than the viewfinder.
Tips	Use the viewfinder for general snapshots (landscape pictures, casual shots, etc.).	Use the monitor when you want to shoot while checking the picture area that the camera actually records. Use when taking macro pictures or close-ups of a person or flower.

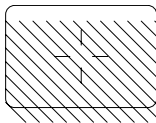

- The camera records a wider area than the image in the viewfinder.
- As you get closer to the subject, the actual image recorded becomes lower than the one in the viewfinder (see left).

If correct focus cannot be obtained

When the subject you want to focus on is not in the center of the frame and you cannot position the AF target mark on it, you can focus the camera on another point at roughly the same distance (focus lock) and take the picture as explained below.

Determine the position of the subject after focusing (Focus Lock)

1 Open the lens barrier fully.

- The lens extends and the monitor turns on.

2 Position the AF target mark on the subject you want to focus on.

- When shooting a hard-to-focus subject, point the camera at an object about the same distance away as the subject.

AF target mark

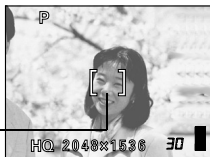

Monitor

3 Press the shutter button halfway until the green lamp lights.

- The focus, exposure, and white balance are locked.
- When the green lamp blinks, the focus is not locked. Release your finger from the shutter button, re-position your subject and press the shutter button halfway again.



Shutter button

4 Keeping the shutter button pressed halfway, recompose your shot.

Green lamp



5 Press the shutter button fully.

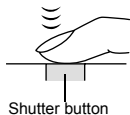

TIPS

The green lamp blinks.

→ You are too close to the subject. Take the picture at least 50 cm away from the subject. When the distance from the camera to the subject is less than 50 cm/1.6 ft, select the macro mode.

☞ “Macro mode shooting” (P.65)

→ Depending on the subject, the focus may not be locked.

☞ “Subjects that are difficult to focus on” (P.55)

Subjects that are difficult to focus on

Under certain types of conditions, the auto focus may not work properly. If this happens, focus on an object with high contrast at the same distance as the intended subject (focus lock), recompose your shot and then take the picture. If the subject has no vertical lines, hold the camera vertically and focus the camera using the focus lock function by pressing the shutter button halfway, then return the camera to the horizontal position while keeping the button pressed halfway and take the picture.

The green lamp blinks.
The subject cannot be brought into focus.



Subject with low contrast



Subject with an extremely bright area in the center of the frame

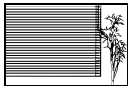

Subject without vertical lines

The green lamp lights, but the subject cannot be brought into focus.



Subjects at different distances

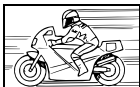

Fast-moving subject



The subject to be focused on is not in the center of the frame

Night scene mode



Setting the mode to NIGHT SCENE allows you to take landscape shots at night under optimum conditions. In this mode, the shutter speed is not fixed at up to 1/30 second even when the flash is activated. Depending upon the subject or shooting conditions, the shutter speed may be extended up to 4 seconds.







Night scene mode
(Flash off)



Night scene mode
(Flash fires)

4

Shooting basics

- 1 Open the lens barrier fully.**
 - The lens extends and the monitor turns on.
- 2 Press Δ () to display the virtual dial screen (the screen for selecting the shooting mode).**
- 3 Press $\triangleleft \triangleright$ to select , then press OK .**
 - Night scene mode is set and the camera returns to the shooting mode.
 - The night scene mark  appears on the monitor.
- 4 Take the picture.**

Arrow pad (Δ ∇ \triangleleft \triangleright)

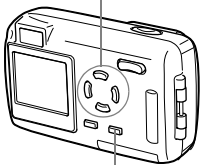

OK 

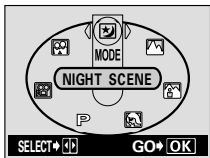

Virtual dial screen



Note

- The flash is set independent of night scene mode.  “Using the flash” (P.62)
- Since the shutter speed is slow, make sure you stabilize the camera by using a tripod.





You can record movies with this camera. Recorded movies can be played back or stored as the other still pictures using the index function.

- 1 Open the lens barrier fully.**
 - The lens extends and the monitor turns on.
- 2 Press Δ () to display the virtual dial screen.**

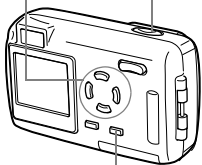
Arrow pad (Δ ∇ \triangleleft \triangleright)
Shutter button



- 3 Press \triangleleft \triangleright to select , then press OK .**
 - Movie recording is set and the camera returns to the shooting mode.
 - The  mark and the total recordable time depending on the card memory capacity are displayed on the monitor.

OK 

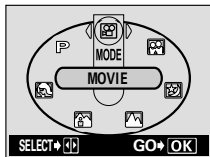

Virtual dial screen

- 4 Decide the composition while looking at the image on the monitor.**
- 5 Press the shutter button halfway.**
 - The focus and white balance are locked.
- 6 Press the shutter button fully to start recording.**



Seconds remaining 

- 7 Press the shutter button again to stop recording.**
 - The orange lamp blinks while the movie is stored on the card.
 - When the remaining recording time has been used up, recording stops automatically.



Note

- The magnification of the optical zoom cannot be changed during movie recording. The zoom is fixed in the Wide position. To use the zoom, set "DIGITAL ZOOM" to "ON".
 - ▶ "Using the digital zoom" (P.60)
- During movie recording, the flash is disabled.
- It takes longer to store movies than still pictures.
- The seconds remaining varies depending on the record mode and the amount of space available on the card.
- You cannot record movies with sound.

Zoom

Telephoto and wide-angle shooting are possible at 3× magnification (the optical zoom limit, equivalent to 35 mm –105 mm on a 35 mm camera). By combining the optical zoom with the digital zoom, zoom magnification can be increased to a maximum of approximately 15×. To use the zoom in  mode, set the camera to digital zoom.

Magnification of the digital zoom

When SQ2 (640 × 480) is selected: up to 5×

Other record modes: up to 4×

Using the optical zoom

1 Open the lens barrier fully.

- The lens extends and the monitor turns on.

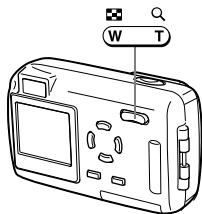

2 Press the zoom button.

Wide-angle: Press the zoom button toward W to zoom out.

Telephoto: Press the zoom button toward T to zoom in.

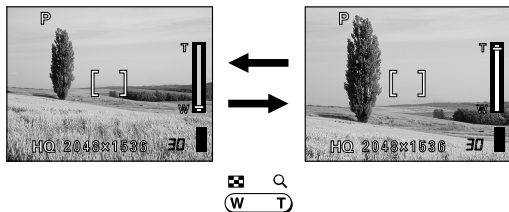

3 Take the picture.

Using the digital zoom

- 1 Open the lens barrier fully.**
 - The lens extends and the monitor turns on.
- 2 Press OK .**
 - The top menu is displayed.

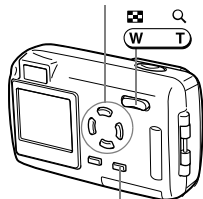

Arrow pad (   )





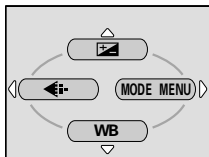

OK 

- 3 Press  to select MODE MENU.**

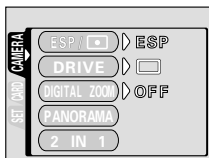

- 4 Press   to select the CAMERA tab, then press .**



- 5 Press   to select DIGITAL ZOOM, then press .**

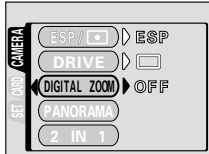

6 Press Δ ∇ to select ON, then press OK [OK] .

- Press **OK** [OK] again to exit the menu and return to shooting status.

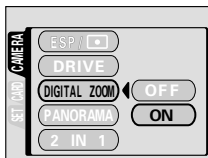

7 Press the zoom button toward T.

- The white area of the zoom indicator indicates the optical zoom. If the digital zoom is set to ON, a red area appears on the zoom indicator. The digital zoom is enabled when the zoom button is pressed toward T until it reaches the optical zoom limit.

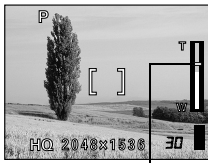

The cursor moves up and down on the zoom indicator according to the zoom magnification.

8 Take the picture.



Note

- Pictures taken with the digital zoom may appear grainy.
- Camera movement is likely to occur at higher magnifications. Stabilize the camera with a tripod, etc. to avoid camera movement.
- Turning off the monitor deactivates the digital zoom, and the image is taken according to the optical zoom setting. While DIGITAL ZOOM is set to ON, it will be automatically enabled next time you turn the monitor on.
- You cannot use the optical and digital zoom in Self-Portrait mode.

Using the flash



Select the flash mode best suited to the light conditions and the effect you want to achieve.

- 1 Open the lens barrier fully.**
 - The lens extends and the monitor turns on.
- 2 Press \blacktriangleright (⚡) to set flash mode.**
 - The current flash setting is displayed.
 - Each time you press \blacktriangleright , the flash mode changes in the following sequence:
“AUTO” – “ Red-eye reduction” –
“ Fill-in flash” – “ Flash off”.

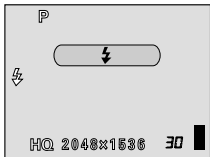
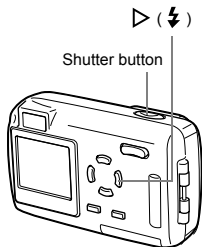

- 3 Press the shutter button halfway.**
 - When the flash is ready to fire, the orange lamp lights steady.
- 4 Press the shutter button fully to take the picture.**

Flash working range

W : Approx. 0.5 m to 3.6 m (1.6 ft. to 11.8 ft.)

T : Approx. 0.2 m to 2 m (0.7 ft. to 6.6 ft.)



TIPS

The orange lamp or the (flash standby) indication blinks.

→ The flash is charging. Wait until the lamp goes off.



Note

- The flash does not fire in the following situations:
When shooting a bright subject (AUTO,) , in the movie record mode, during Panorama shooting.
- The flash may not give you the optimum result in macro mode, especially with wide-angle shooting. Check the resulting picture on the monitor.

●Auto-flash (No indication)

The flash fires automatically in low light or backlight conditions. To shoot a subject with backlight, position the AF target mark over the subject.

●Red-eye reduction flash (👁)

The light from the flash may make the subject's eyes appear red in the picture. The red-eye reduction flash mode reduces this phenomenon by emitting pre-flashes before firing the regular flash. This helps accustom the subject's eyes to the bright light and minimizes the red-eye phenomenon.



The subject's eyes appear red.



Note

- After the pre-flash, it takes about 1 second before the shutter is released. Hold the camera firmly to avoid camera movement.
- Effectiveness may be limited if the subject is not looking directly at the pre-flashes, or if the shooting range is too far. Individual physical characteristics may also limit effectiveness.

●Fill-in flash (⚡)

The flash fires regardless of the available light. This mode is useful for eliminating shadows on the subject's face (such as shadows from tree leaves), in a backlight situation, or for correcting the color shift produced by artificial lighting (especially fluorescent light).



Note

- The fill-in flash may not have the desired effect under excessively bright light.

●Flash off (🚫)

The flash does not fire even in low light conditions. Use this mode in situations where flash photography is not desired or is prohibited, such as in an art museum. You can also use this mode when you want to shoot a natural-looking twilight or night scene.



Note

- Since a slow shutter speed is automatically selected in low light situations when in the flash off mode, the use of a tripod is recommended to prevent your pictures from being blurred by camera movement.

5 Advanced shooting

Macro mode shooting



The macro mode allows you to shoot at a distance of 20 cm to 50 cm (0.7 ft. to 1.6 ft.) from your subject. Regular photographs can be taken, but the camera may take time to focus on distant subjects.



Normal shooting



With the macro mode

- 1 Open the lens barrier fully.**
 - The lens extends and the monitor turns on.
- 2 Press \triangleleft (🌸) to set macro mode.**
 - The setting changes between ON and OFF each time \triangleleft is pressed. When the macro mode is selected, 🌸 is displayed on the monitor.

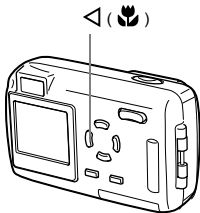

- 3 Take the picture.**

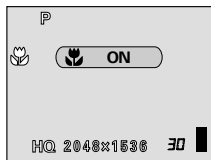

Note

- If you are close to a subject, the picture in the viewfinder is different from the area that the camera actually records. For macro mode shooting, we recommend using the monitor.
- If you use the flash in macro shooting, shadows may be conspicuous and the correct exposure may not be achieved.







This function lets you take pictures using the self-timer. Fix the camera securely on a tripod for self-timer shooting. This function is useful for taking pictures where you want to be included in the photograph.

1 Open the lens barrier fully.

- The lens extends and the monitor turns on.

2 Press ∇ () to set the self-timer mode.

- The setting changes between  / OFF,  and  each time ∇ is pressed. When the self-timer mode is selected,  is displayed on the monitor.

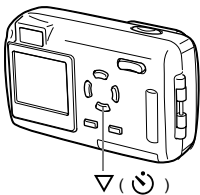

5

3 Take the picture.

- The self-timer/remote control lamp lights for approximately 10 seconds, then starts blinking. After blinking for approximately 2 seconds, the picture is taken.
- The self-timer mode is automatically canceled after one shot.

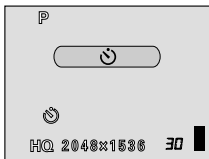

Self-timer/Remote control lamp



Remote control shooting









Shooting is possible using the remote control device (sold separately in some regions). This is useful when you want to take a picture with yourself in it or a night scene, without touching the camera.

1 Mount the camera on a tripod or place it on a stable, flat surface.

2 Open the lens barrier fully.

- The lens extends and the monitor turns on.

3 Press ∇ () to set the remote control mode.

- The setting changes between  /  OFF,  and  each time ∇ is pressed. When remote control is selected,  is displayed on the monitor.

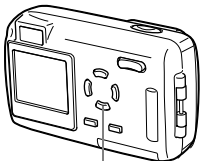

∇ ()

4 Point the remote control device at the remote control receiver on the camera.

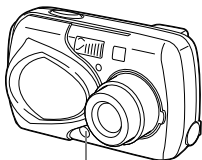
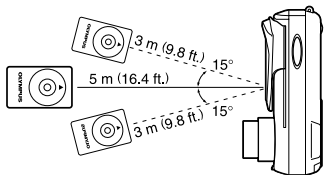

Remote control receiver

5 Press the shutter button on the remote control device.

- The focus and exposure are locked. The self-timer/remote control lamp on the camera blinks for about 2 seconds before taking the picture.

5

Advanced shooting





TIPS

The self-timer/remote control lamp does not blink after pressing the shutter button on the remote control device.

- The remote control device may be too far from the camera. Move closer to the camera and press the shutter button on the remote control device again.
- The battery of the remote control device may be exhausted.
 - ☞ “How to replace the battery (CR2025) of the remote control device” (P.132)

To cancel the remote control mode.

- The remote control mode is not canceled automatically after shooting. Perform step 3 on page 67 and set the mode to  /  OFF.



Note



- If the remote control receiver is exposed to strong light, the effective signal distance may be reduced or shooting may not take place.
- To shoot sequential shots using the remote control device, press and hold the shutter button on the remote control device. If the camera does not receive the remote control signal properly, sequential shooting may stop.

Selecting the metering area **ESP**

In a backlight situation, your subject may appear dark if the picture is taken with the normal metering value (Digital ESP metering). In this case, by changing the metering area to the center of the screen (Spot metering), the subject can be shot with optimal exposure regardless of the background light.

ESP (No indication): Meters the center of the screen and the area around it separately to obtain the optimum exposure.

Spot metering (): Meters only the center of the screen to obtain the appropriate exposure for the subject.

- 1 In the shooting mode top menu, select MODE MENU → CAMERA → ESP/, and press .**

 "How to use the menus" (P.40)

Arrow pad (   )

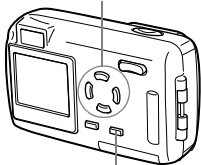

OK 

- 2 Press   to select , then press OK .**
 - Press OK  again to exit the menu.
- 3 Take the picture.**

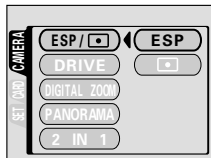



Advanced shooting

Sequential shooting



This function () allows you to take a rapid succession of still pictures by pressing and holding the shutter button (at 1 frame per second in HQ mode, up to 4 pictures for Stylus 400 DIGITAL/μ[mju:] 400 DIGITAL).

As you can choose the best picture from a series of sequential shots, you are recommended to use this mode when taking a moving subject. Focus and exposure are locked at the first frame. White balance is measured and locked every frame. You can also erase unwanted shots afterwards.  “Single-frame erase” (P.94)

- 1 In the shooting mode top menu, select MODE MENU → CAMERA → DRIVE → , and press OK .**

 “How to use the menus” (P.40)

- Press **OK**  again to exit the menu.

Arrow pad (   )

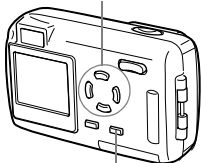

OK 

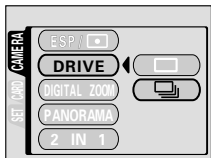

- 2 Take the picture.**

- Press the shutter button fully and keep it pressed. The camera will take pictures in sequence until you release the button.
- You are recommended to use the viewfinder for sequential shooting. During sequential shooting, the subject does not appear on the monitor.

Panorama shooting

You can take advantage of panorama shooting with the Olympus xD-Picture Card. Panorama shooting lets you connect pictures with overlapping edges into a single panoramic picture, using the CAMEDIA Master software contained on the CD-ROM provided.

- 1 In the shooting mode top menu, select MODE MENU → CAMERA → PANORAMA, and press \triangleright .**

"How to use the menus" (P.40)

- The PANORAMA mode is set.

Arrow pad (\triangle ∇ \triangleleft \triangleright)

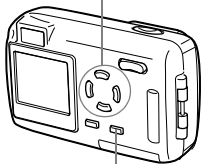

3 Make sure that the edges of the pictures overlap, then take your pictures.

- Focus, exposure and white balance are set by the first picture. Do not select an extremely bright subject (such as the sun) for the first picture.
- You cannot adjust the zoom after the first picture.
- Panorama shooting is possible for up to 10 pictures.

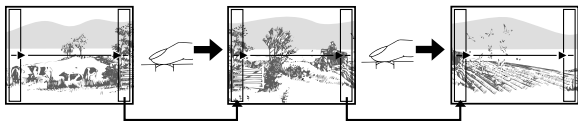

When shooting, make sure that the edges (right/left/top/bottom) of the images overlap, so that you will know which pictures should be connected.

5

Advanced shooting

- When you have taken 10 pictures, a warning mark is displayed.



4 Press OK to finish panorama shooting.

- The frame on the screen disappears and the camera returns to the normal shooting mode.



Note

- The panorama mode is only available with Olympus xD-Picture Card.
- Your computer's memory may be insufficient if you take too many panorama pictures in HQ or SHQ mode. You are recommended to use SQ mode for panorama shooting.
- During panorama shooting, the flash and sequential shooting are not available.
- The camera itself cannot connect panorama pictures. The CAMEDIA Master software is necessary to connect the pictures.

This function allows you to combine two pictures taken in succession and store them as a single picture. You can combine two different subjects in one picture.



Picture when played back

- 1 In the shooting mode top menu, select MODE MENU → CAMERA → 2 IN 1, and press \blacktriangleright .**

"How to use the menus" (P.40)

- The two-in-one picture mode is set.

Arrow pad (\blacktriangle \blacktriangledown \blacktriangleleft \blacktriangleright)

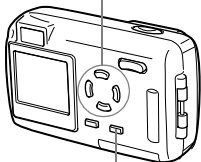

OK

- 2 Take the first shot while observing your subject on the monitor.**

- The subject will be positioned on the left in the combined picture.

- 3 Take the second shot.**



- The subject will be positioned on the right in the combined picture.



Picture when shooting







Note

- During two-in-one picture shooting, the panorama and sequential shooting are not available.
- When the battery power is exhausted ( is displayed), the flash automatically turns off.
- The two-in-one picture mode is canceled when **OK**  is pressed or the lens barrier is closed. Press **OK**  to cancel the two-in-one picture mode after the first shot has been taken. The first picture will not be stored.

Selecting a record mode



You can select a record mode in which to take pictures or shoot movies. Choose the best record mode for your purposes (printing, editing on a PC, website editing, etc.). For details of the different record modes, resolutions and number of pictures storable on the card, refer to the table on the next page. The numbers in the table are approximate.

Record mode	Description	Quality	File size
SHQ	<ul style="list-style-type: none">• A high quality mode.• Fewer images can be saved to a card.• Takes longer to store the images.	Clearer  	Larger  
	Uses		
<ul style="list-style-type: none">• Good for printing.• Can be enlarged to A4 (210mm × 297mm / 8.3" × 11.7") size.• Good for processing on a PC.			
HQ	<ul style="list-style-type: none">• Factory default setting.		
	Uses		
	<ul style="list-style-type: none">• Good for editing on a PC or printing in postcard size.		
SQ1/SQ2	<ul style="list-style-type: none">• The resolutions are smaller than in SHQ or HQ.• A standard quality mode.• More images can be saved to a card.	Normal	Smaller
	Uses		
	<ul style="list-style-type: none">• Attaching images to e-mail or simply viewing them on a PC.		

Still Picture Record Modes for Stylus 400 DIGITAL/μ[mju:] 400 DIGITAL

Record mode	Resolution (No. of pixels)	Memory capacity in number of shots (using a 16 MB card)
SHQ	2272 × 1704	5
HQ		16
SQ1	2048 × 1536	20
SQ2	1600 × 1200	24
	1280 × 960	38
	1024 × 768	58
	640 × 480	99

Still Picture Record Modes for Stylus 300 DIGITAL/μ[mju:] 300 DIGITAL

Record mode	Resolution (No. of pixels)	Memory capacity in number of shots (using a 16 MB card)
SHQ	2048 × 1536	6
HQ		20
SQ1	1600 × 1200	24
SQ2	1280 × 960	38
	1024 × 768	58
	640 × 480	99

Movie Record Modes

Record mode	Resolution (Frames per second)	Memory capacity in sec. per movie
HQ	320 × 240 (15 frames/sec)	16
SQ	160 × 120 (15 frames/sec)	70

- In the  mode, the total recording time is displayed on-screen. Total recording time depends on the memory capacity of the card.



Note

- The card memory capacity listed in the table is approximate.
- The number of remaining pictures may change according to the subject or factors like whether print reservations have been made or not. In certain instances, the number of remaining pictures displayed on the monitor may not change even when a picture is taken or a stored image is erased.

1 In the shooting mode top menu, press \triangleleft to select \leftarrow .

"How to use the menus" (P.40)

Arrow pad (\triangle ∇ \triangleleft \triangleright)

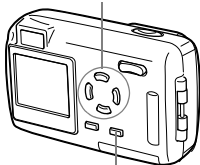

OK

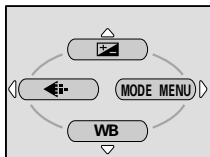

2 Press \triangle ∇ to select the desired record mode.

- For still pictures, you can choose from SHQ, HQ, SQ1 and SQ2.

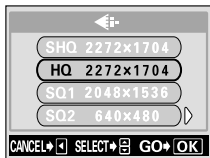

Screen differs between Stylus 300 (μ [mju:] 300) and Stylus 400 (μ [mju:] 400) .

- For movies, you can choose HQ or SQ.
 Go to step 4.

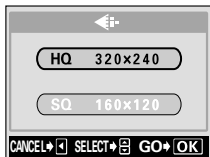

5

Advanced shooting

- 3** If you choose SQ2 for still pictures, press \triangleright to display the screen for selecting the resolution. Press \triangle ∇ to choose a resolution.

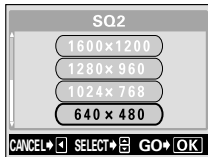

Screen differs between Stylus 300 (μ [mju:] 300) and Stylus 400 (μ [mju:] 400) .

- 4** Press OK \equiv .
- Press OK \equiv again to exit the menu.



TIPS

- **Resolution**

The number of pixels (horizontal \times vertical) used when saving an image. If the image will be printed, higher resolutions (larger numbers) are recommended so that the image will be clearer. However, higher resolutions make the file size (amount of data) larger, so the number of pictures that can be saved will be fewer.

- **Resolution and picture size on a computer screen**

When a picture is transferred to a computer, the size of the picture on the computer screen varies depending on the computer's monitor setting. For instance, a picture taken in 1024 \times 768 resolution is the same size as the screen if you set the picture to 1 \times when the monitor setting is 1024 \times 768. However, if the monitor setting is over 1024 \times 768 (such as 1280 \times 1024), the picture only takes up part of the screen.

Varying the image brightness (Exposure compensation)

In some situations, you may get better results when the exposure that the camera sets is compensated (adjusted) manually. You can adjust the brightness in the range of ± 2.0 in $1/3$ steps. When the setting is changed, you can check the result on the monitor.

- 1 In the shooting mode top menu, press Δ to select .**

 "How to use the menus" (P.40)

Arrow pad (Δ ∇ \triangleleft \triangleright)

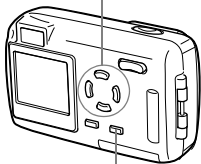

OK 

- 2 Press Δ ∇ to select the exposure compensation value.**

- Select a [+] value to brighten the image or a [-] value to darken the image.

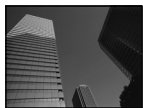
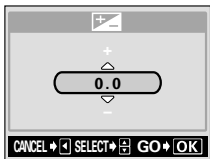

-2.0



0.0



+2.0

- 3 Take the picture.**



TIPS

- Often bright subjects (such as snow) will turn out darker than their natural colors. Adjusting toward [+] makes these subjects closer to their real shades. For the same reason, adjust toward [-] when shooting dark subjects.



Note

- If the flash is used, the image brightness (exposure) may differ from the intended brightness (exposure).
- Exposure compensation cannot correct the image if the surroundings of the subject are extremely bright or dark.

Color reproduction differs depending on the light conditions. For instance, when daylight, the setting sun or tungsten lighting are reflected on white paper, the shade of white produced will be slightly different for each. By setting the WB (white balance), you can achieve more natural-looking colors.

- 1 In the shooting mode top menu, press ∇ to select WB.**

 "How to use the menus" (P.40)

Arrow pad (\triangle ∇ \triangleleft \triangleright)

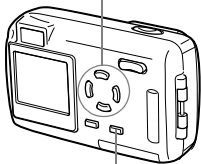



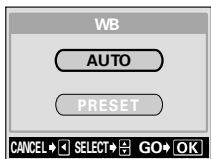

OK 

- 2 Press \triangle ∇ to select AUTO or PRESET.**











AUTO (No indication) : The white balance is adjusted automatically so that colors look natural irrespective of the light source.

PRESET : Lets you select a white balance according to the light source.

-  **(Sunlight)** : For natural colors under a clear sky.
-  **(Overcast)** : For natural colors under a cloudy sky.
-  **(Tungsten)** : For natural colors under tungsten lighting.
-  **(Fluorescent)** : For natural colors under fluorescent lighting.

3 Press OK .

- If you selected AUTO, press **OK**  again to exit the menu.
- If you selected PRESET, the screen for choosing a preset white balance is displayed.

4 Press   **to select** , ,  **or** , **then press OK** .

- The menu goes off.

5 Take the picture.

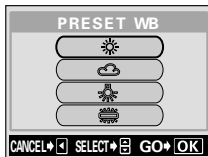

Note

- White balance may not be effective under some special light sources.
- After setting a white balance mode other than AUTO, play back the picture and check the colors on the monitor.
- When the flash is fired with a white balance setting other than AUTO, colors may appear different in the resulting picture from the colors you see on the monitor.

6 Playback

Viewing still pictures



1 Press .

- The monitor turns on and displays the last picture taken. (Single-frame playback)

Arrow pad ()

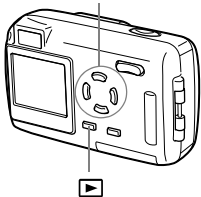

2 Use the arrow pad to play back other pictures.

Jumps to the picture 10 frames back. ()

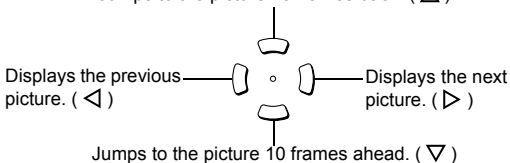

3 Press to cancel playback.

- The monitor and camera turn off.



Note

- If the camera is not used for over 3 minutes, the monitor and the power turn off automatically.

QUICK VIEW

This function lets you play back pictures while the camera is in the shooting mode. This is useful when you want to check shooting results and resume shooting quickly.

Functions available in normal playback mode are also available in QUICK VIEW.

1 Press  twice quickly (double-click) while in the shooting mode.

- The camera immediately enters the playback mode and displays the last picture taken. (Single-frame playback)

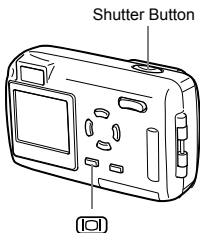

2 Press the shutter button halfway to return to the shooting mode.

The camera returns to shooting mode, and is ready to take pictures.

Close-up playback

Pictures displayed on the monitor can be enlarged in steps up to 4 times the original size.

1 Use the arrow pad to display the still picture you want to enlarge.

- You cannot enlarge pictures with .

2 Press the zoom button toward T.

- By using the arrow pad while the enlarged picture is displayed, you can shift the picture in the desired direction, enabling you to view a different portion.
- To return the picture to the original size (1×), press the zoom button toward W.

Arrow pad (   )

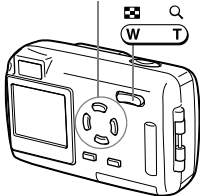

6

Playback



Note

- Pictures cannot be stored in an enlarged state.



This function lets you show several pictures at the same time on the monitor. The number of pictures shown can be 4, 9 or 16. “Selecting the number of pictures” (P.87)

- 1 In the single-frame playback mode, press the zoom button toward W.**

Arrow pad ()

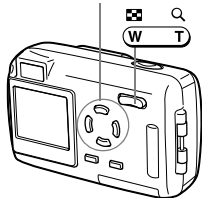

- Use the arrow pad to select the picture.
 - : Moves to the previous frame.
 - : Moves to the next frame.
 - : Jumps to the previous index display (the frames before the top left frame).
 - : Jumps to the next index display (the frames following the bottom right frame).



- To return to single-frame playback, press the zoom button toward T.

Selecting the number of pictures

This function lets you select the number of pictures in an index display from 4, 9 and 16.



- 1** In the playback mode top menu, select **MODE MENU** → **SETUP** → , and press .

 "How to use the menus" (P.40)

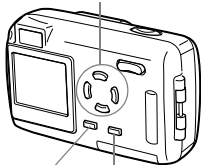
Arrow pad (   )



 **OK** 

- 2** Press   to choose the number of pictures (4, 9 or 16), then press **OK** .

• Press **OK**  again to exit the menu.

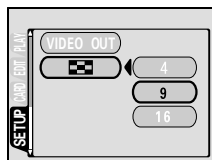



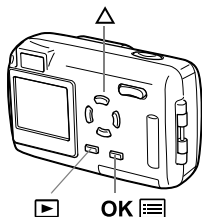

This function displays still pictures stored on the card one after another. Only the first frame of movies is played back.

- 1 Display a still picture, then press **OK**  to display the top menu.



- 2 Press **△** () to start the slideshow.
- 3 Press **OK**  to stop the slideshow.

- The slideshow will not stop until you cancel it by pressing **OK** .

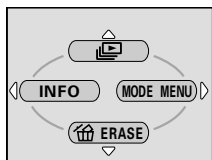

6



Note

- You are recommended to use the optional AC adapter when running a slideshow for a long period of time. If the battery is used, the camera will stop the slideshow after about 30 minutes and turn off.

Playback on a TV

Use the Video cable provided with the camera to play back recorded images (still pictures and movies) on your TV.

- 1 Make sure that the camera and the TV are turned off. Connect the Video cable to the VIDEO OUT jack on the camera and the video input terminal on the TV.**

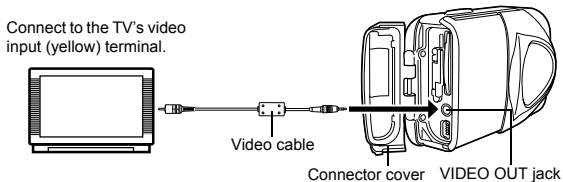

- 2 Turn the TV on and switch to the video input mode.**
 - For details of switching to video input, refer to your TV's instruction manual.
- 3 Press .**
 - The last picture taken is displayed on the TV. Use the arrow pad to select the picture you want to display.
 - The close-up playback, index display and slideshow functions can also be used on a TV screen.



TIPS

- You are recommended to use the optional AC adapter when using the camera with a TV.





Note

- Make sure that the camera's video output signal type is the same as the TV's video signal type.  "Video output selection" (P.110)
- The camera's monitor turns off automatically when the Video cable is connected to the camera.
- Be sure to use the Video cable provided to connect the camera to the TV.
- The picture may appear off-center on the TV screen.
- When pictures are compressed in order to fit the entire picture on the TV screen, a black frame appears around the picture. If the picture is output to a video printer via the TV, the black frame may be printed.

Picture Rotation

Pictures taken with the camera held vertically are displayed horizontally. This function lets you turn such pictures 90 degrees clockwise or counterclockwise so that they are displayed vertically.

- 1 In the playback mode top menu, select MODE MENU → PLAY → , and press .**

Arrow pad (   )

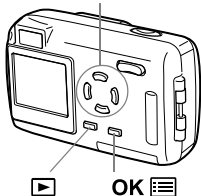

- 2 Press   and select +90° or -90°.**

- The picture is rotated and displayed vertically.
- To close the menu, press **OK**  twice.

6

Playback

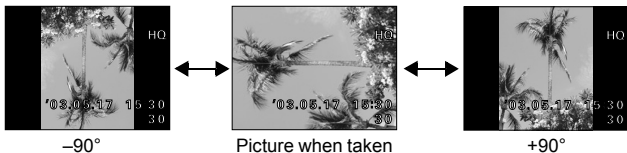

- The following pictures cannot be rotated.
Movies, protected pictures, pictures edited on a PC, pictures taken with another camera
- New picture orientations are saved even when the camera is turned off.

Viewing movies



- 1 Press .**
 - The monitor turns on.

Arrow pad ()

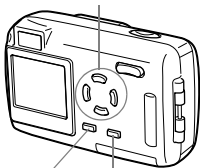

OK

- 2 Use the arrow pad to display the picture with .**
 - ☞ “Viewing still pictures” (P.83)



- 3 Press **OK** .**
 - The top menu is displayed.
- 4 Press to select **MOVIE PLAY**.**

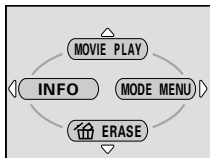

6

Playback

5 Press Δ ∇ to select MOVIE PLAYBACK, then press OK [OK] .

- The movie is played back. When playback ends, the display automatically returns to the beginning of the movie.
- Press **OK** [OK] again after playback ends to display the MOVIE PLAYBACK menu.

PLAYBACK : Plays back the entire movie again.

FRAME BY FRAME :
Plays back the movie manually one frame at a time.

EXIT : Leaves the movie playback mode.

Press Δ ∇ to select from PLAYBACK, FRAME BY FRAME or EXIT, then press **OK** [OK] .



●When FRAME BY FRAME is selected

- Δ : Displays the first frame of the movie.
- ∇ : Displays the last frame of the movie.
- \triangleright : Displays the next frame. The movie can be displayed continuously by holding the button down.
- \triangleleft : Displays the previous frame. The movie can be displayed continuously in reverse by holding the button down.
- OK** [OK] : Displays the MOVIE PLAYBACK menu.









◆ ? TIPS

- Movies can also be played back in the shooting mode using QUICK VIEW. [QV] "QUICK VIEW" (P.84)



- When playing back a movie, the access time will vary depending on the length and record mode of the movie.

You are recommended to protect important pictures to avoid accidentally erasing them. Protected pictures cannot be erased by the single-frame/all-frame erase function.

- 1 Press .**
 - The monitor turns on.
- 2 Use the arrow pad to display the picture you want to protect.**
 - ➡ "Viewing still pictures" (P.83)
- 3 Press **OK** .**
 - The top menu is displayed.
- 4 In the top menu, select **MODE MENU** → **PLAY** → , and press .**
 - ➡ "How to use the menus" (P.40)
- 5 Press   to select **ON**, then press **OK** .**
 - To cancel protection, select **OFF**.
- 6 Press **OK**  to exit the menu.**
 - The Protect icon  appears on the screen.

Arrow pad (   )

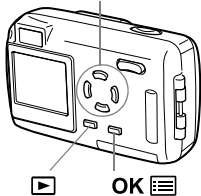

Displayed when a picture is protected.



Note

- Protected pictures cannot be erased by the single-frame/all-frame erase function, but they are all erased by formatting.



You can erase recorded pictures either one at a time or all at once.



Note

- You cannot erase pictures that are protected. Cancel the protection before erasing such pictures.
- Once erased, pictures cannot be restored. Check each picture before erasing to avoid accidentally erasing pictures you want to keep. “Protecting pictures” (P.93)

Single-frame erase

This function erases only the picture displayed on the monitor. The all-frame erase function can be used to erase all the pictures on the card at once.

“All-frame erase” (P.95)

- 1 Press .**
 - The monitor turns on.
- 2 Use the arrow pad to display the picture you want to erase.**
 “Viewing still pictures” (P.83)
- 3 Press **OK** .**
 - The top menu is displayed.
- 4 Press to select .**
- 5 Press to select **YES**, then press **OK** .**
 - The picture is erased and the menu is closed.

Arrow pad ()

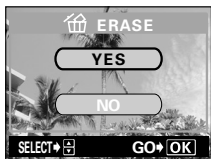
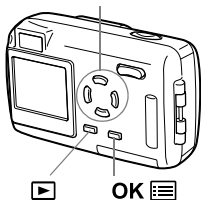

All-frame erase

This function erases all the pictures on the card.

- 1** In the playback mode top menu, select **MODE MENU** → **CARD** → **CARD SETUP**, and press **▶**.

☞ "How to use the menus" (P.40)

Arrow pad (**▲** **▼** **◀** **▶**)

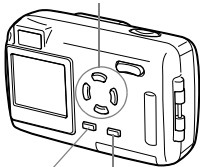

▶ **OK**

- 2** Press **▲** **▼** to select **ALL ERASE**, then press **OK** .

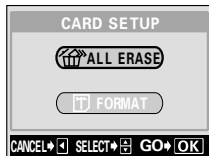

- 3** Press **▲** **▼** to select **YES**, then press **OK** .

• All the pictures are erased.



6

Playback

Editing still pictures

This function lets you edit still pictures and store them as new pictures. The following editing operations are possible.

- BLACK&WHITE** : Converts pictures into black and white pictures and stores them as new pictures.
- SEPIA** : Converts pictures into sepia-toned pictures and stores them as new pictures.
-  : Changes the picture size to 640 × 480 or 320 × 240 and stores the picture as a new picture.

1 Press .

- The monitor turns on.

2 Use the arrow pad to display the still picture you want to edit.





- ☞ "Viewing still pictures" (P.83)

3 Press **OK .**

- The top menu is displayed.

4 In the top menu, select **MODE MENU → **EDIT**, then choose each item.**

- ☞ "How to use the menus" (P.40)

- Select **BLACK&WHITE**  P.96
- Select **SEPIA**  P.97
- Select   P.97

Arrow pad (   )

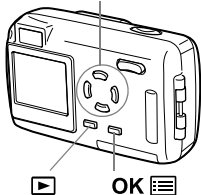



6

Playback

Creating black and white pictures

5 Select **BLACK&WHITE, then press .**

6 Press   to select **BLACK&WHITE, then press **OK** .**

- The **BUSY** bar is displayed, then the camera returns to the playback mode. The black and white picture is stored as a separate picture from the original.



- To cancel the editing, select CANCEL and press **OK**  .





Note

- You cannot create black and white movies.
- You cannot create a black and white picture if there is insufficient memory space on the card.

Creating sepia-toned pictures

5 Select **SEPIA**, then press **▷** .

6 Press **△ ▽** to select **SEPIA**, then press **OK**  .

- The BUSY bar is displayed, then the camera returns to the playback mode. The sepia-toned picture is stored as a separate picture from the original.
- To cancel the editing, select CANCEL and press **OK**  .





Note

- You cannot create sepia-toned movies.
- You cannot create a sepia-toned picture if there is insufficient memory space on the card.

Resizing pictures

5 Select  , then press **▷** .

6 Press **△ ▽** to select the new picture size, then press **OK**  .

- The BUSY bar is displayed, then the camera returns to the playback mode. The newly created picture is stored as a separate picture from the original.
- To cancel the resizing, select CANCEL, and press **OK**  .

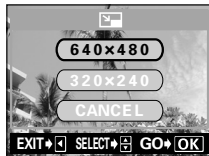



Note

- Resizing is not possible in the following cases.
Movies, pictures edited on a PC, or when there is insufficient memory space on the card.
- If the size of the selected picture is 640 × 480, you cannot select 640 × 480.

Creating an index

9 frames extracted from the movie are displayed as an index to show the movie at one glance. Indexes can be stored on the card as still pictures.

- 1 Use the arrow pad to select a picture with .

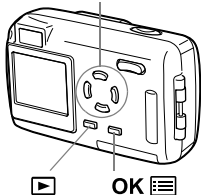

Arrow pad (   )



- 2 In the top menu, select **MOVIE PLAY** → **INDEX**.

 "How to use the menus" (P.40)



- 3 Press   to select **INDEX**, then press **OK** .

- To cancel the editing, select **CANCEL** and press **OK** .



6

Playback

- The 9 frames extracted from the movie appear as an index display, then the camera returns to the playback mode. The index is stored as a new picture.

TIPS

- The index is stored as a still picture in a different record mode from the original movie.

Record mode when the movie was shot	Record mode when stored as an index
HQ	SQ2 (1024 × 768 pixels)
SQ	SQ2 (640 × 480 pixels)



Note

- The interval between the frames that are automatically picked out varies depending on the length of the movie.
- An index consists of 9 frames.
- You cannot create an index if there is insufficient memory space on the card.

7 Useful functions

Saving the settings (All Reset)

This function lets you choose whether or not to save the current camera settings after the power is turned off. The settings affected by All Reset are listed on the next page.

The All Reset setting (ON/OFF) applies to all the modes. If All Reset is set to OFF in one mode, this setting applies to all the other modes, both shooting and playback.

ON : All settings are returned to the factory default settings after the power is turned off.

OFF : The settings made before the power is turned off are saved.

- In the top menu, select MODE MENU → SETUP → ALL RESET → OFF or ON, and press OK** .

 "How to use the menus" (P.40)

- Press **OK**  again to exit the menu.

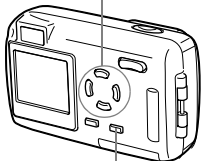

Arrow pad (   )









OK 



Note

- Mode menu tab functions (ALL RESET, , , ) , etc.) do not return to factory default settings with ALL RESET.

●Functions that All Reset affects

Function	Factory default setting	Ref. page
LCD	ON	P.50
Shooting mode	P (PROGRAM AUTO)	P.47
DRIVE	 (for still pictures)	P.70
DIGITAL ZOOM	OFF (1×)	P.60
FLASH	AUTO	P.62
	±0	P.79
ESP/ 	ESP	P.69
WB	AUTO	P.81
	HQ	P.75
	OFF	P.65
	OFF	P.67



This function lets you format a card. Formatting prepares cards to receive data. Before using non-Olympus cards or cards which have been formatted on a PC, you must format the card with this camera.

All existing data, including protected pictures, are erased when the card is formatted. Make sure that you save or transfer important data to a PC before formatting a used card.

1 In the top menu, select MODE MENU → CARD → CARD SETUP, and press \triangleright .

"How to use the menus" (P.40)

- Shooting mode
The FORMAT screen is displayed.
- Playback mode
The CARD SETUP screen is displayed.

2 If the FORMAT screen is displayed, press \triangle ∇ to select YES.

If the CARD SETUP screen is displayed, press \triangle ∇ to select FORMAT, then press OK . When the FORMAT screen appears, press \triangle to select YES.

Arrow pad (\triangle ∇ \triangleleft \triangleright)

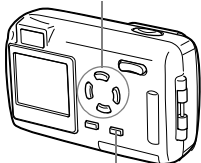

OK

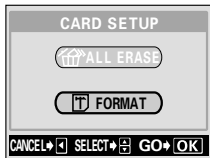
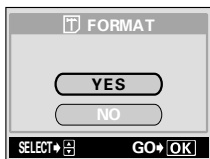

3 Press OK .

- The BUSY bar is displayed and the card is formatted.

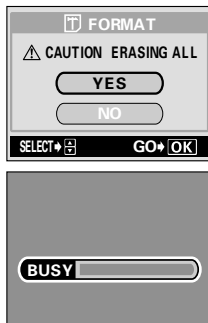

Note

Never do the following during formatting, as they may cause the card to malfunction.

- Open the card cover.
- Remove the battery.
- Connect or disconnect the AC adapter.

Displaying shooting information INFO

This function lets you display detailed shooting information on the monitor for 3 seconds in the playback mode. For details of the information displayed, see "Monitor indications" (P.10).

1 Pressing \triangleleft in the playback mode top menu displays the full amount of shooting information on the monitor (ON).

 "How to use the menus" (P.40)

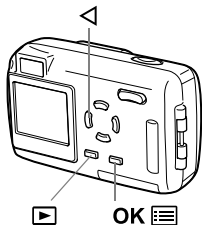

- To turn INFO off, press **OK**  to bring up the top menu and press \triangleleft (OFF).

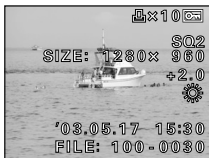

When INFO is ON



When INFO is OFF





Note

- If the picture has been taken with a different camera, only the date, frame number and battery level are displayed when INFO is set to ON.

Adjusting the monitor brightness

This function lets you adjust the brightness of the monitor. The brightness can be adjusted in either the shooting mode or the playback mode.



- 1 In the top menu, select MODE MENU → SETUP → , and press .**

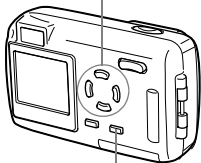

 "How to use the menus" (P.40)

Arrow pad (   )



OK 

- 2 Press   to adjust the brightness of the monitor, and when you have set the desired level, press OK .**

- Pressing  brightens the monitor, and pressing  darkens it.
- Press **OK**  again to exit the menu.



Viewing a picture immediately after shooting (Rec View)

You can choose whether or not to display the picture you have just taken on the monitor.

- ON** : The picture being recorded to the card is displayed. This is useful for making a brief check of the picture you have just taken. You can resume shooting anytime during Rec View.
- OFF** : The picture being recorded to the card is not displayed. This is useful when you want to prepare for your next shot while the previous picture is being recorded.

1 In the shooting mode top menu, select **MODE MENU** → **SETUP** → **REC VIEW** → **OFF** or **ON**, and press **OK** .

 "How to use the menus" (P.40)

- Press **OK**  again to exit the menu.

Arrow pad (   )

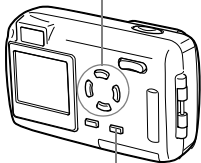

OK 

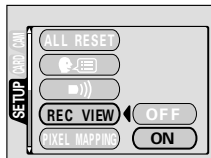

Turning the beep sound off



This function lets you turn on/off the beep sound used for warnings, etc. The beep sound can be adjusted in either the shooting mode or the playback mode.

- 1 In the top menu, select **MODE MENU** → **SETUP** → **■)))** → **OFF** or **ON**, and press **OK**

"How to use the menu" (P.40)

- Press **OK** again to exit the menu.

Arrow pad ()

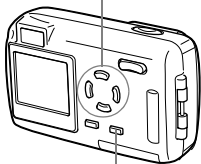

OK

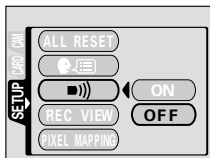

Pixel Mapping

The Pixel Mapping feature allows the camera to check and adjust the CCD and image processing functions. It is not necessary to operate this function frequently. Approximately once a year is recommended. Wait a few minutes after the monitor is used or continuous shots are taken to allow for proper performance of the Pixel Mapping function.

1 In the shooting mode top menu, select MODE MENU → SETUP → PIXEL MAPPING, and press \blacktriangleright .

- START is displayed.

 "How to use the menus" (P.40)

2 Press OK .

- The BUSY bar is displayed during Pixel Mapping. When Pixel Mapping is finished, the screen returns to the mode menu.

Arrow pad (\blacktriangle \blacktriangledown \blacktriangleleft \blacktriangleright)

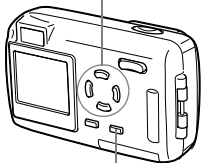

OK 

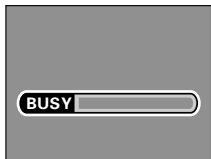



- If you accidentally turn the camera off during Pixel Mapping, start again from step 1.

Video output selection

You can select NTSC or PAL according to your TV's video signal type. You can change the NTSC/PAL setting in either the shooting mode or the playback mode.

- 1 In the top menu, select MODE MENU → SETUP → VIDEO OUT → NTSC or PAL, and press OK .**

 "How to use the menus" (P.40)

- Press **OK**  again to exit the menu.
- The factory default setting varies depending on the area where you purchased this camera.

Arrow pad (   )

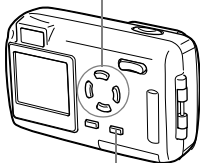

OK 

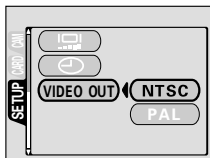

TIPS



TV video signal types & main regions

Check the video signal type before using the camera.

NTSC : Japan, Taiwan, Korea, North America

PAL : European countries, China

8 Print settings

How to print pictures



Several different printing options are available when you want to print out pictures.

● **Printing at a photo lab that supports DPOF or printing on a DPOF-compatible printer**

Store the print reservation data on the card. Print reservation allows you to save printing data (number of prints, date/time information, etc.) with the pictures stored on the card.

What is DPOF?

DPOF is short for Digital Print Order Format. DPOF is the format used to record automatic print information from digital cameras.

If a card containing print reservation data is taken to a photo lab that supports the DPOF format, the pictures can be printed according to the DPOF reservations. Or pictures can be printed out at home on a personal DPOF-compatible printer.

● **Printing on an Olympus CAMEDIA P-400 or P-200 digital printer**

Printing is possible directly from a card containing print reservation data without using a PC. For more details, refer to the printer's instruction manual. The xD-Picture Card cannot be inserted directly into the printer. Use the card adaptor (sold separately).

● **Transferring pictures to a PC and printing them from a printer connected to the PC**

If your PC has software applications installed that support JPEG images (Internet browser, Paint Shop Pro, Photoshop, etc.), you can print out your pictures on a printer connected to the PC. (Printing is also possible using CAMEDIA Master software.) Check your software before printing. For details, refer to the application software's instructions.

For instructions on how to transfer images, or connect the camera to a PC, see "DIGITAL CAMERA-PC CONNECTION OPERATION MANUAL" on the CD-ROM.



TIPS

Picture size and printing

The resolution of a computer/printer is generally based on the number of dots (pixels) per square inch. This is called dpi (dots per inch). The higher the dpi value, the better the printed results. Keep in mind, however, that the dpi of the picture does not change. This means that when you print an image with a higher resolution, the size of the printed picture will be smaller. Although you can print magnified images, picture quality will decrease.

If you want to print large, high-quality pictures, set the record mode as high as possible when taking the pictures. "Selecting a record mode" (P.75)



Note

- DPOF reservations set by another device cannot be changed by this camera. Make changes using the original device.
- If a card contains DPOF reservations set by another device, entering reservations using this camera may overwrite the previous reservations.
- DPOF reservation for 999 frames can be made on one card.
- Reservations may not be able to be made when space on the card is limited. "CARD FULL" is displayed.
- Even if an image appears with the message "PICTURE ERROR", it may be possible to make print reservations. In such a case, the print reservation icon () does not appear when an image is displayed for full view. appears when multiple images are displayed (index-display mode), allowing you to confirm the print reservation.
- Not all functions may be available on all printers or at all photo labs.
- Print reservation may take considerable time when saving printing data to a card.

All-frame reservation



Use this feature to print all the pictures stored on the card. You can select whether or not to include the shooting date and time. The reserved number of prints is one per frame. Use single-frame reservation to reserve multiple prints of a particular frame.

1 Play back a still picture.

- You cannot print pictures with .

2 In the top menu, select MODE MENU → PLAY → , and press .

- If print reservation data is already stored on the card, the PRINT ORDER SETTING screen appears, giving you the choice of resetting the data or keeping it. “Resetting print reservation data” (P.116)

3 Press to select , then press OK .

4 Press to select NO, DATE or TIME, then press OK .

- The PRINT ORDER screen is displayed.

NO : The pictures are printed without the date and time.

DATE : All the pictures are printed with the shooting date.

TIME : All the pictures are printed with the shooting time.

5 Press to select SET, then press OK .

- To cancel the print reservation settings, select CANCEL and press OK .
- The print reservation data is stored on the card and the screen returns to the playback menu.

Arrow pad ()

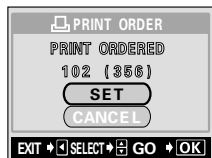
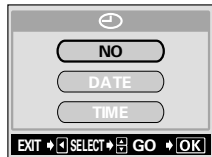
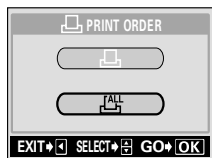
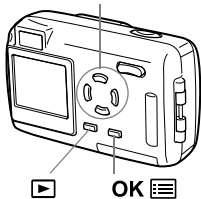

Single-frame reservation



Use this feature to print only selected pictures. This function can also alter details (number of prints, date, etc.) of previously made reservations. Display the picture to be printed and select the desired number of prints.

1 Play back a still picture.

- You cannot print pictures with

2 In the top menu, select **MODE MENU** → **PLAY** → , and press .

- If data is already stored on the card, the PRINT ORDER SETTING screen appears, giving you the choice of resetting the data or keeping it.
 "Resetting print reservation data" (P.116)

Arrow pad ()

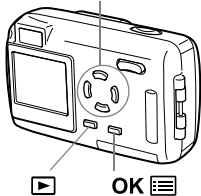

3 Press to select , then press **OK** .

- If multiple pictures are shown in an index display, return to single-picture playback first.

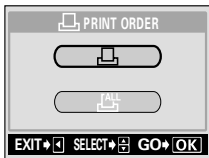

4 Press to select the frame you want to print.



5 Press to select the desired number of prints, then press **OK** .

- The maximum number of prints you can set is 10. If you select 0, no prints will be made.

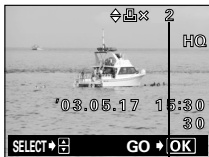

The number of prints reserved is displayed.

6 Press Δ ∇ to select NO, DATE or TIME, then press OK \equiv .

- The \square PRINT ORDER screen appears.

NO : The picture is printed without the date and time.

DATE: The picture is printed with the shooting date.

TIME : The picture is printed with the shooting time.



7 Press Δ ∇ to select SET, then press OK \equiv .

- To cancel the print reservation settings, select CANCEL and press OK \equiv .
- The print reservation data is stored on the card and the screen returns to the playback menu.



Only the print reservation mark is displayed for single print.



Resetting print reservation data

This function allows you to reset all the print reservation data for pictures stored on the card.



1 Play back a still picture.

- You cannot print pictures with .

2 In the top menu, select MODE MENU → PLAY → , and press .

- If print reservation data is already stored on the card, the  PRINT ORDER SETTING screen appears.

3 Press to select RESET, then press **OK** .

- If there is no print reservation data stored on the card, the  PRINT ORDER SETTING screen does not appear.
- To cancel resetting, select KEEP and press **OK** .



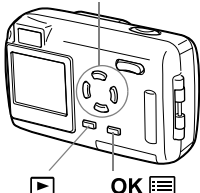





Arrow pad (   )



 PRINT ORDER SETTING Screen

9 Miscellaneous

Error codes

Monitor indication	Possible cause	Corrective action
 NO CARD	The card is not inserted, or it cannot be recognized.	Insert a card or insert a different card. Wipe the gold contacts with a commercially available cleaning paper and insert the card again. If the problem persists, format the card. If the card cannot be formatted, it cannot be used.
 CARD ERROR	There is a problem with the card.	Use a different card. Insert a new card.
 WRITE-PROTECT	Writing to the card is prohibited.	Read-only has been set using a computer. Use the computer again to cancel the read-only setting.
 CARD FULL	The card is full. No more pictures can be taken or no more information such as print reservation can be recorded.	Replace the card or erase unwanted pictures. Before erasing, download important images to a PC.
 NO PICTURE	There are no pictures on the card.	The card contains no pictures. Record pictures.
 PICTURE ERROR	There is a problem with the selected picture and it cannot be displayed.	Use image processing software to view the picture on a PC. If that cannot be done, the image file is damaged.
	The card is not formatted.	Format the card.
 CARD COVER OPEN	The card cover is open.	Close the card cover.

Monitor indication	Possible cause	Corrective action
 <p>Y/M/D</p>	The date and time are not set.	Set the date and time.

Troubleshooting

●The camera does not work.

The camera does not turn on or function buttons do not respond.		
Possible cause	Corrective action	Ref. Page
The power is off.	Open the lens barrier fully to turn on the camera.	P.25
The battery is exhausted.	Charge the battery.	P.13
The battery is temporarily unable to function because of the cold.	Warm the battery by putting it in your pocket for a while.	—
The camera is in the sleep mode.	Operate the camera (press the shutter button or the zoom button).	P.25
There is condensation* inside the camera.	Wait until the camera dries before turning it on again.	—
The camera is connected to a PC.	The camera will not operate while it is connected to a PC.	—

*Condensation: When it is cold outside, the water vapor in the air is rapidly cooled and turns to droplets of water.

Condensation occurs when the camera is suddenly taken from a cold place into a warm room.

No picture is taken when the shutter button is pressed.		
Possible cause	Corrective action	Ref. Page
The lens barrier is closed.	Open the lens barrier fully.	P.25
The power is off.	Open the lens barrier fully.	P.25
The movie just taken is being written to the card.	Release your finger from the shutter button. When the orange lamp stops blinking, resume shooting.	P.57
The card is full.	Erase unwanted pictures or insert a new card. Before erasing, download important images to a PC.	P.94
The memory gauge is full.	Wait until there is room in the memory gauge.	P.13
There is a problem with the card.	Refer to the "Error codes".	P.117



The green and orange lamps on the right of the viewfinder blink simultaneously.		
Possible cause	Corrective action	Ref. Page
The battery is exhausted.	Charge the battery.	P.17

The subject is not displayed on the monitor.		
Possible cause	Corrective action	Ref. Page
The monitor was turned off before closing the lens barrier.	If All Reset in the SETUP tab of the mode menu is set to "OFF," the camera settings before the lens barrier was closed remain unchanged. Turn on the monitor, and close the lens barrier.	P.101
You are taking sequential shots.	No image appears on the monitor during sequential shooting.	P.70

The colors of the image in the monitor are blurred when the camera is focusing.		
Possible cause	Corrective action	Ref. Page
The colors of the image in the monitor may be blurred when the shutter button is pressed halfway.	This is not a malfunction. The image will be displayed clearly when focusing is complete.	—

The flash does not fire.		
Possible cause	Corrective action	Ref. Page
The flash is set to the flash off mode.	Select a flash mode other than flash off.	P.62
The subject is illuminated.	If you want the flash to fire on a brightly illuminated subject, set the flash to fill-in mode.	P.62
The camera is in movie mode.	The flash is disabled in the movie mode.	P.57
Panorama mode is set.	The flash does not fire in the panorama mode. Cancel the panorama mode.	P.71

The monitor is hard to see.		
Possible cause	Corrective action	Ref. Page
Vertical lines appear on the monitor.	This sometimes occurs when the camera is aimed at a bright subject in sunlight. It is not a malfunction.	P.51
The brightness is not adjusted properly.	Select  in the mode menu and then adjust the brightness.	P.106
The monitor is exposed to direct sunlight.	Block the sunlight with your hand.	—

Pictures you have taken do not appear on the monitor.		
Possible cause	Corrective action	Ref. Page
The power is off.	With the lens barrier closed, press  to turn the monitor on.	P.26
The camera is in the shooting mode.	Press  quickly twice, or close the lens barrier and then press  to switch to the playback mode.	P.26, 84
There are no pictures on the card.	NO PICTURE appears on the monitor. Record pictures.	—
There is a problem with the card.	Refer to the “Error codes”.	P.117
The camera is connected to a TV.	The monitor does not function when the video cable is connected to the camera.	P.89

The date recorded with the image data is wrong.		
Possible cause	Corrective action	Ref. Page
The date/time is not set.	Set the date/time. The clock adjustment is not factory-preset.	P.30
The battery is exhausted.	When the battery runs down, the date/time setting is canceled or becomes inaccurate. Insert a charged battery and reset the date and time.	P.18, 30
The camera has been left with the battery removed.	If the camera is left for about a day with the battery removed, the date/time setting is canceled. Set the date/time again.	P.30

The settings are returned to the factory default settings when the camera is turned off.		
Possible cause	Corrective action	Ref. Page
All Reset is set to ON.	Select the SETUP tab in the mode menu and set All Reset to OFF.	P.101
Remove the battery just after turning the camera off.	Removing the battery just after turning the camera off may cause the settings to return to the factory default settings. Wait a few seconds before removing the battery.	—

● **The image quality is poor.**

The picture is too bright.		
Possible cause	Corrective action	Ref. Page
The flash was set to the fill-in flash mode.	Select a flash mode other than fill-in flash.	P.62
The subject was excessively illuminated.	Adjust the exposure compensation toward minus (-) or change the camera position.	P.79

The picture is too dark.		
Possible cause	Corrective action	Ref. Page
The flash was blocked by your finger.	Hold the camera correctly, keeping your fingers away from the flash.	P.32
The subject was out of the working range of the flash.	Shoot within the flash working range.	P.62
The flash was set to the flash off mode.	Select a flash mode other than flash off.	P.62
The subject was too small and was backlit.	Set the flash to fill-in mode, or use the spot metering mode.	P.62, 69
Bright subjects such as a snow-covered landscape will turn out darker than their natural colors.	Adjust the exposure compensation towards plus [+].	P.79

The colors of pictures taken indoors look unnatural.		
Possible cause	Corrective action	Ref. Page
Indoor lighting can affect the picture's colors.	Set the white balance according to the lighting.	P.81
There is no white in the subject.	Include something white in the picture, or shoot using the fill-in flash mode.	P.62
The white balance setting is wrong.	Adjust the white balance according to the light source.	P.81













The picture has obscured edge(s).		
Possible cause	Corrective action	Ref. Page
The lens was partly blocked by your finger or the strap.	Hold the camera correctly, keeping your fingers and the strap away from the lens.	P.32
The subject was too close.	Check the actual picture area by using the monitor to take the picture.	P.53

The picture is out of focus.		
Possible cause	Corrective action	Ref. Page
The camera moved when the shutter button was pressed.	Hold the camera correctly and press the shutter button gently. Camera movement occurs easily with slower shutter speeds. When you take a picture with the flash off mode in a night scene or a dark situation, use a tripod, or hold the camera firmly.	P.32
The subject is too close.	Use the macro mode to take pictures at a distance of less than 50 cm from the subject. You can take pictures up to 20 cm from the subject.	P.65
The camera may not be correctly focused even if the green lamp is lit.	Use the focus lock to focus on an object at the same distance from the camera as the subject, then recompose your picture.	P.54
The lens was wet or dirty.	Wipe the water or dirt off the lens. Use a commercially available blower brush and then wipe with a Lens cleaner to remove dust. Mold may form on the lens surface if the lens is left dirty.	—













The battery soon runs down.		
Possible cause	Corrective action	Ref. Page
The camera is being used in a cold environment.	Battery performance deteriorates in low temperatures. Keep the camera warm by putting it inside your coat or clothing.	—
The camera misread the remaining battery power.	When the power consumption fluctuates greatly, the camera may turn off without displaying the low battery warning. Replace with a charged battery.	P.18

Menu List













● Shooting mode menus (A / / / / / /)

Top menu	Tab	Function	Setting	Ref. page
MODE MENU	CAMERA	ESP/ 	ESP, 	P.69
		DRIVE	 , 	P.70
		DIGITAL ZOOM	OFF, ON	P.60
		PANORAMA		P.71
		2 in 1		P.73
	CARD SETUP	CARD SETUP	YES, NO	P.103
		ALL RESET	OFF, ON	P.101
			日本語, ENGLISH, FRANÇAIS, DEUTSCH, ESPAÑOL	P.28
			OFF, ON	P.108
		REC VIEW	OFF, ON	P.107
		PIXEL MAPPING		P.109
				P.106
		VIDEO OUT	NTSC, PAL	P.110
		SHQ, HQ, SQ1, SQ2	P.75	
		-2.0 – +2.0 (in 1/3 EV steps)	P.79	
WB		AUTO, PRESET ( ,  ,  , )	P.81	







● Shooting mode menus ()

Top menu	Tab	Function	Setting	Ref. page
MODE MENU	CAMERA	ESP/ 	ESP, 	P.69
		DIGITAL ZOOM	OFF, ON	P.60
	CARD	CARD SETUP	YES, NO	P.103
		SETUP	ALL RESET	OFF, ON
			日本語, ENGLISH, FRANÇAIS, DEUTSCH, ESPAÑOL	P.28
			OFF, ON	P.108
	PIXEL MAPPING			P.109
				P.106
				P.30
			VIDEO OUT	NTSC, PAL
			HQ, SQ	P.75
			-2.0 – +2.0 (in 1/3 EV steps)	P.79
WHITE BALANCE			AUTO, PRESET ( ,  ,  , )	P.81

● Playback mode menus (Still picture)





Top menu	Tab	Function	Setting	Ref. page
MODE MENU	PLAY		OFF, ON	P.93
			0, +90°, -90°	P.90
			 , 	P.111
	EDIT	BLACK&WHITE	BLAC&KWHITE, CANCEL	P.96
		SEPIA	SEPIA, CANCEL	P.97
			640 × 480, 320 × 240, CANCEL	P.97
	CARD SETUP	CARD SETUP	ALL ERASE, FORMAT	P.95, 103
	SETUP	ALL RESET	OFF, ON	P.101
			日本語, ENGLISH, FRANÇAIS, DEUTSCH, ESPAÑOL	P.28
			OFF, ON	P.108
				P.106
				P.30
		VIDEO OUT	NTSC, PAL	P.110
			4, 9, 16	P.87
				P.88
INFO				P.105
			YES, NO	P.94

● Playback mode menus ()





Top menu	Tab	Function	Setting	Ref. page
MODE MENU	PLAY		OFF, ON	P.93
		CARD SETUP	ALL ERASE, FORMAT	P.95, 103
	SETUP	ALL RESET	OFF, ON	P.101
			日本語, ENGLISH, FRANÇAIS, DEUTSCH, ESPAÑOL	P.28
			OFF, ON	P.108
				P.106
				P.30
		VIDEO OUT	NTSC, PAL	P.110
			4, 9, 16	P.87
		MOVIE PLAYBACK	PLAYBACK, FRAME BY FRAME, EXIT	P.91
MOVIE PLAY	INDEX	INDEX, CANCEL	P.99	
INFO			P.105	
			YES, NO	P.94

Factory default settings





● Shooting mode

	AUTO
	OFF
Shooting mode	P
Zoom	Wide
Monitor	On
ESP/ 	ESP
	HQ
	±0
DRIVE	<input type="checkbox"/> (Single-frame shooting)
DIGITAL ZOOM	OFF
PANORAMA	OFF
2 in 1	OFF
WB	AUTO
REC VIEW	ON
	OFF

● Playback mode

	OFF
	OFF
INFO	OFF
	0°
	9

●Others

	ON
ALL RESET	ON
	ENGLISH
	±0
	2003.01.01
VIDEO OUT	*

* Settings differ according to the region where the camera is sold.

List of functions by shooting mode

Mode \ Function	P						
	✓	✓	✓	✓	✓	✓	✓
	✓	✓	✓	✓	✓	✓	-
	✓	✓	✓	✓	✓	✓	✓
	✓	✓	✓	✓	✓	✓	✓
Optical zoom	✓	✓	✓	✓	✓	-	✓*
Virtual dial	✓	✓	✓	✓	✓	✓	✓
ESP/ 	✓	✓	✓	✓	✓	-	✓
	✓	✓	✓	✓	✓	✓	✓
	✓	✓	✓	✓	✓	✓	✓
	✓	✓	✓	✓	✓	✓	-
DIGITAL ZOOM	✓	✓	✓	✓	✓	-	✓
PANORAMA	✓	✓	✓	✓	✓	✓	-
2 IN 1	✓	✓	✓	✓	✓	✓	-
WB	✓	✓	✓	✓	✓	✓	✓
CARD SETUP	✓	✓	✓	✓	✓	✓	✓
ALL RESET	✓	✓	✓	✓	✓	✓	✓
	✓	✓	✓	✓	✓	✓	✓
	✓	✓	✓	✓	✓	✓	✓
REC VIEW	✓	✓	✓	✓	✓	✓	-
PIXEL MAPPING	✓	✓	✓	✓	✓	✓	✓
	✓	✓	✓	✓	✓	✓	✓
	✓	✓	✓	✓	✓	✓	✓
VIDEO OUTPUT	✓	✓	✓	✓	✓	✓	✓

✓ : available -: not available

* The optical zoom cannot be changed during shooting.

Camera maintenance

● After use

Close the lens barrier.

● Cleaning the camera

1 **Close the lens barrier to turn the camera off.**

Make sure that the monitor is turned off.

2 **Remove the battery (P.19). (If you are using an AC adapter, unplug the AC adapter from the camera first before removing the plug from the wall outlet.)**

3 **Exterior:**

→ Wipe gently with a soft cloth. If the camera is very dirty, soak the cloth in mild soapy water and wring well. Wipe the camera with the damp cloth and then dry it with a dry cloth. If you have used the camera at the beach, use a cloth soaked in clean water and well wrung.

Monitor and viewfinder:

→ Wipe gently with a soft cloth.

Lens:

→ Blow dust off the lens with a commercially available blower, then wipe gently with a lens cleaning paper.

Card:

→ Wipe gently with a soft, dry cloth.



Note

- Do not use strong solvents such as benzene or alcohol, or chemically treated cloths.
- Cleaning should be done only after the battery has been removed or the AC adapter has been disconnected.
- Mold may form on the lens surface if the lens is left dirty.

●How to replace the battery (CR2025) of the remote control device

- 1** Turn the screw on the bottom of the remote control device counterclockwise to loosen.

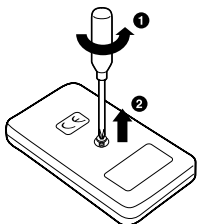

- 2** Turn the remote control device over, and remove the cover. With the battery facing up, remove the old battery and insert a new battery as shown.

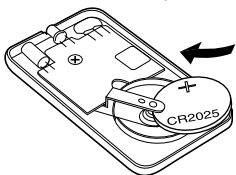

- 3** Replace the cover, turn the remote control device over, and turn the screw on the bottom clockwise to tighten.

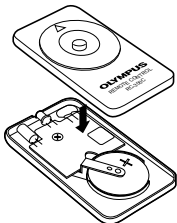

Note

- Do not use the remote control device underwater.
- Do not apply excessive force to the remote control device.
- Never heat the remote control device or dispose of it in fire.
- Do not wash the remote control device with water.
- The temperature range in which the remote control device can be used is -10°C to 40°C (14°F to 104°F).

Specifications

- Product type : Digital camera (for shooting and displaying)
- Recording system
- Still picture : Digital recording, JPEG (in accordance with Design rule for Camera File system (DCF)), Exif 2.2, Digital Print Order Format (DPOF), PRINT Image Matching II
- Movie : QuickTime Motion JPEG support
- Memory : xD-Picture Card (16 – 256MB)

No. of storable pictures (when a 16 MB Card is used)

Resolution	Record mode/ No. of storable pictures			
	Stylus/μ[mju:] 400 DIGITAL		Stylus/μ[mju:] 300 DIGITAL	
2272 × 1704	SHQ	5	—	—
	HQ	16		
2048 × 1536	SQ1	20	SHQ	6
			HQ	20
1600 × 1200	SQ2	24	SQ1	24
1280 × 960		38	SQ2	38
1024 × 768		58		58
640 × 480		99		99

Record mode	Resolution (Frames/sec)	Memory capacity in sec. per movie
HQ	320 × 240 (15 frames/sec)	16
SQ	160 × 120 (15 frames/sec)	70

No. of effective pixels

- Stylus/μ[mju:]
300 DIGITAL : 3,200,000 pixels
- Stylus/μ[mju:]
400 DIGITAL : 4,000,000 pixels

Image pickup device

Stylus/ μ [mju:] : 1/2.5" CCD solid-state image pickup, 3,340,000
300 DIGITAL pixels (gross)

Stylus/ μ [mju:] : 1/2.5" CCD solid-state image pickup, 4,230,000
400 DIGITAL pixels (gross)

Lens : Olympus lens 5.8 mm to 17.4 mm (equivalent to 35
mm to 105 mm lens on 35 mm camera), F3.1 to F5.2

Photometric system : Digital ESP metering, Spot metering

Shutter speed : 1/2 to 1/1000 sec. (max. 4 sec. in Night scene mode)

Shooting range : 0.5 m (1.6 ft.) to ∞ (normal)
0.2 m (0.7 ft.) to ∞ (macro mode)

Viewfinder : Optical real image viewfinder

Monitor : 1.5" TFT color LCD display, 134,000pixels

Outer connector : DC-IN jack, USB connector (mini-B), VIDEO OUT
jack

Automatic calendar : 2000 – 2099
system

Weatherproof : Equivalent to IEC Standard publication 529 IPX4
feature (under OLYMPUS test conditions)

Operating environment

Temperature : 0 to 40°C (32°F to 104°F) (operation)
-20 to 60°C (-4°F to 140°F) (storage)

Humidity : 30% to 90% (operation)/10% to 90% (storage)

Power supply : Specified lithium ion rechargeable battery or AC
adapter

Dimensions : 99 mm (W) × 56 mm (H) × 33.5 mm (D)
(3.9" × 2.2" × 1.3")
(excluding protrusions)

Weight : 165 g (0.4 lb.) (without battery or card)

SPECIFICATIONS ARE SUBJECT TO CHANGE WITHOUT ANY NOTICE
OR OBLIGATION ON THE PART OF THE MANUFACTURER.

Glossary of terms

AE (Automatic Exposure)

The camera's built-in exposure meter automatically sets the exposure.

CCD (Charge-Coupled Device)

This converts light passing through the lens into electrical signals. On this camera, light is picked up and converted into RGB signals to build a single image.

DCF (Design rule for Camera File system)

A standard for image files by the Japan Electronics and Information Technology Industries Association (JEITA).

Digital ESP (Electro-Selective Pattern) Light Metering

This determines the exposure by metering and calculating the light levels in the center and other areas of the image separately.

DPOF (Digital Print Order Format)

This is for saving desired print settings on digital cameras. By entering which images to print and the number of copies of each, the user can easily have the desired images printed by a printer or print lab that supports the DPOF format.

Effective Pixel Resolution

The number of pixels used in the CCD to create the image.

EV (Exposure Value)

A system for measuring exposure. EV 0 is when the aperture is at F1 and the shutter speed is 1 second. The EV then increases by 1 each time the aperture increases by one F stop or the shutter speed increases by one increment. EV can also be used to indicate brightness and ISO settings.

Exposure

The amount of light used to capture an image. The exposure is determined by the time the shutter is open (shutter speed) and the amount of light that passes through the lens (aperture).

Gross Pixel Resolution

The total number of pixels in a CCD. Not all pixels are used to create the image.

JPEG (Joint Photographic Experts Group)

A compression format for color still images. Photographs (images) shot using this camera are recorded onto the card in JPEG format when the record mode is set to SHQ, HQ or SQ. By downloading these images to a personal computer, users can edit them using graphics application software or view the images using an Internet web browser.

NTSC (National Television Systems Committee) / PAL (Phase Alternating Line)

Television formats. NTSC is mainly used in Japan, North America and Korea. PAL is mainly used in Europe and China.

Pixels

A pixel is the smallest unit (dot) used to make up an image. Clear large-sized printed images require millions of pixels.

Resolution

The size of the picture expressed as the number of dots (pixels) that make up the image. For instance, a picture taken in 640 x 480 resolution is the same size as the PC screen when the monitor setting is 640 x 480. However, if the monitor setting is 1024 x 768, the picture only takes up part of the screen.



Sleep Mode

A mode designed to save battery life. The camera automatically enters the sleep mode if you do not operate it for a certain time. To activate the camera again, touch any button (shutter button, arrow pad, etc.).

TFT (Thin-Film Transistor) Color Monitor

A color monitor constructed using thin-film technology.

A

- AC adapter 20
- Adjusting the monitor
brightness  106
- AF target mark 9, 50
- All reset 101
- All-frame erase  95
- All-frame reservation 113
- Arrow pad 9, 39
- Auto flash 63
- Auto focus 55
- Auto white balance 81

B

- Batteries 17
- Battery check 13
- Battery compartment cover . . 9, 18
- Beep sound )) 108
- Black and white picture 96

C

- Camera movement warning . . . 10
- Card 22
- Card check 27
- Card cover 8, 23
- Card setup 103
- Close-up playback  85
- Connector cover 8, 22, 89



D

- Date/time setting  30
- DC-IN jack 8, 20
- DC-IN jack cover 8
- Digital zoom 60
- DPOF 111
- Drive 44

E

- Erasing pictures 94
- Error codes 117
- ESP metering 69
- Exposure compensation  79

F

- Fill-in flash  63
- Flash 8, 62
- Flash charge 50
- Flash off  64
- Flash stand-by 50
- Fluorescent lamp  81
- Focus lock 54
- Formatting 103
- Fully pressed 51

G

- Green lamp 9, 50, 52



H

- Halfway pressed 51
- HQ 75



I

- Index (Creating an index) 99
- Index display  86
- Information display 105

L

- Landscape shooting  48
- Landscape + Portrait shooting
 48
- Language setting  28
- Lens 8
- Lens barrier 8
- Lithium ion battery 17

M

Macro mode shooting 	65
Memory gauge	13
Metering	69
Mode menu	39, 44
Monitor	9, 35
Monitor button	9
Movie 	49
Movie play	43
Movie playback	92





N

Night Scene 	49
No. of storable still pictures	11
NTSC	110

O

OK/Menu button	9, 39
Optical zoom	59
Orange lamp	9, 52
Overcast 	81





P

PAL	110
Panorama	71
Picture rotation 	90
Pixel mapping	109
Playback mode	12
Playing back pictures on a TV	89
Portrait 	48
Print settings 	111
Protecting 	93
Program auto	48







Q

Quick View	84
------------	----

R

Record mode 	75
Rec View	107
Red-eye reduction flash 	63
Remote control 	67
Remote control Receiver	8, 67
Resizing 	97
Resolution	76, 78

S

Seconds remaining	11
Self portrait 	49
Self-timer 	66
Sepia	97
Sequential shooting 	70
Shooting mode	10, 47
Shortcut menus	39, 42
SHQ	75
Shutter button	8, 33
Single-frame erase 	94
Single-frame playback	83
Single-frame reservation	114
Single-frame shooting	44
Slideshow 	88
Spot metering 	69
SQ	75
Strap	16
Strap eyelet	9, 16
Sunlight 	81

T

Top menu	39
Tripod socket	9
Tungsten light 	81
Two-in-one picture 2 IN 1	73

U

USB connector 8

V

Video cable 89

Video output 110

Video out jack 8

Viewfinder 9, 51

W

White balance **WB** 81

X

xD-Picture Card 22

Z

Zoom button 9, 59, 85, 86

OLYMPUS

<http://www.olympus.com/>

OLYMPUS OPTICAL CO., LTD.

San-Ei Building, 22-2, Nishi Shinjuku 1-chome, Shinjuku-ku, Tokyo, Japan
Customer support (Japanese language only): Tel. 0426-42-7499 Tokyo

OLYMPUS AMERICA INC.

Two Corporate Center Drive, Melville, NY 11747-3157, U.S.A. Tel. 631-844-5000

Technical Support (USA)

24/7 online automated help: <http://support.olympusamerica.com/>

Phone customer support: Tel. 1-888-553-4448 (Toll-free)

Our phone customer support is available from 8 am to 10 pm
(Monday to Friday) ET

E-Mail: distec@olympus.com

Olympus software updates can be obtained at: <http://olympus.com/digital/>

OLYMPUS OPTICAL CO. (EUROPA) GMBH.

Premises/Goods delivery: Wendenstrasse 14-18, 20097 Hamburg, Germany
Tel. 040-23 77 33

Letters: Postfach 10 49 08, 20034 Hamburg, Germany

European Technical Customer Support:

Please visit our homepage <http://www.olympus-europa.com>

or call our TOLL FREE NUMBER : **00800 - 67 10 83 00**

for Austria, Belgium, Denmark, Finland, France, Germany, Italy, Luxembourg,
Netherlands, Norway, Portugal, Spain, Sweden, Switzerland, United Kingdom

- Please note some (mobile) phone services/provider do not permit access or request an additional prefix to +800 numbers.

For all not listed European Countries and in case that you can't get connected
to the above mentioned number please make use of the following

CHARGED NUMBERS: **+49 180 5 - 67 10 83** or **+49 40 - 237 73 899**

Our Technical Customer Support is available from 9 am to 6 pm MET (Monday to Friday)

OLYMPUS

CAMEDIA

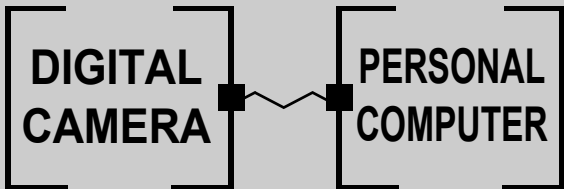

DIGITAL CAMERA — PC CONNECTION
OPERATION MANUAL

How to use your PC to get the most from images taken with your digital camera.

- Thank you for purchasing an Olympus digital camera.
- This manual provides instructions on how to install the USB driver. To ensure correct installation, refer only to these installation procedures.

Introduction

This manual explains in detail how to connect your Olympus digital camera to a computer. Read it carefully and keep it in a safe place for future reference.

About this manual

- The information contained in this manual may be subject to change without notice. For the latest information on the product, please consult your local Olympus representative.
- The information contained in this manual has been compiled by taking all possible measures to ensure its accuracy. However, if you find any errors or incomplete information, please contact your local Olympus representative.
- It is prohibited by copyright laws to duplicate in part or in whole the information contained in this manual, except for personal use. Reproduction without permission of the copyright owner is prohibited.
- The PC screens shown in this manual may differ slightly from the actual displays on some PC models.

Trademarks

- Microsoft and Windows are registered trademarks of Microsoft Corporation.
- Macintosh is a trademark of Apple Computer Inc.
- All other company and product names are registered trademarks and/or trademarks of their respective owners.

INDEX

Flowchart 4

Identifying the OS 6

Windows (98/Me/2000/XP) 8

Macintosh (OS 9/X). 23

**Downloading image files using other OS
(For other OS users). 31**

Windows

Macintosh

Flowchart

By connecting the camera to a computer with the provided USB cable, images on a card can be transferred to the computer. Some OS's (operating systems) may need a special setup before connecting to the camera for the first time. Follow the chart below.

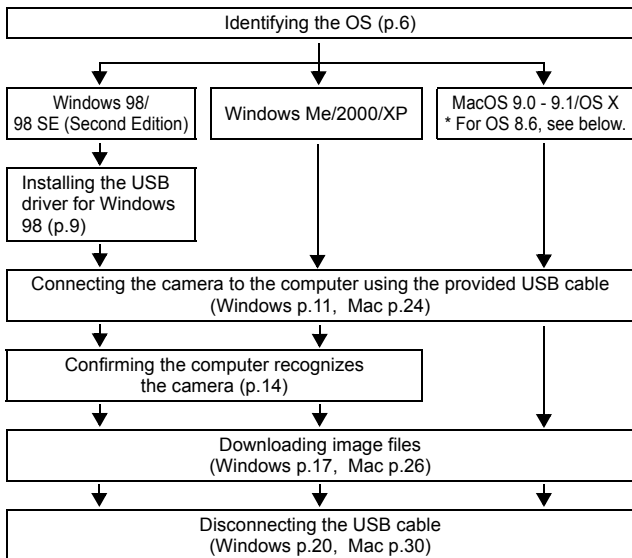

* Even if your computer has a USB connector, data transfer may not function correctly if you are using one of the operating systems listed below or if you have an add-on USB connector (extension card, etc.).

- Windows 95/NT 4.0
- Windows 98/98 SE upgrade from Windows 95
- Mac OS 8.6 or lower (except Mac OS 8.6 equipped with USB MASS Storage Support 1.3.5 installed at the factory)
- Data transfer is not guaranteed on a home-built PC system or PCs with no factory installed OS.



- When connecting the camera to the computer, make sure that there is sufficient remaining battery power. When connected (transmitting) to the computer, the camera does not enter the sleep mode nor will the camera's power turn off automatically. Depending on the camera model, when the battery power runs out or the internal temperature rises, the camera may stop operating automatically. This could cause the computer to malfunction, and any image data (file) being transmitted may be lost. Be careful when downloading files for a long period of time. Use the AC adapter (optional) when downloading files.
- If you connect or disconnect the AC adapter when the camera is connected to the computer and is running on battery power, it may result in the loss of image data on the card or cause a malfunction in the computer. Before connecting or disconnecting the AC adapter, disconnect the camera from the computer and make sure that the camera is turned off.
- To avoid computer malfunctions, do not turn off the camera when the camera is connected to a computer.
- If the camera is connected to the computer via a USB hub, operation may not be stable if there are any compatibility problems between the computer and the hub. In such cases, do not use the hub and connect the camera directly to the computer.



- You can view images using: graphics applications that support the JPEG file format (Paint Shop Pro, Photoshop, etc.); Internet browsers (Netscape Communicator, Microsoft Internet Explorer, etc.); CAMEDIA Master software; or other software. For details on using commercial graphics applications, refer to their instruction manuals.
- QuickTime is needed for playing back movies. QuickTime is included on the provided software CD.
- If you want to process images, make sure to download them to your computer first. Depending on the software, image files may be destroyed if the images are processed (rotated, etc.) while they are on the card.

Identifying the OS

Identify the OS on your computer before connecting the camera. How to identify the OS depends on the computer.

● Windows

1 Double-click the “My Computer” icon on your desktop.

When the “My computer” icon is not on your desktop, click “Control Panel” from the “Start” menu.

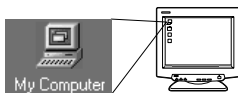

2 Double-click the “Control Panel” icon.



3 Double-click the “System” icon.



The way the file icons inside the folder appear may vary depending on your version of Windows. If you don't see the icon you are looking for, click on “view all Control Panel options” on the left of the window.

4 A System Properties window will appear. Note and record the “System:” information.

Confirm that your system is Windows 98, 98 SE, Me, 2000 Professional or Windows XP, then press “OK” to close the window.

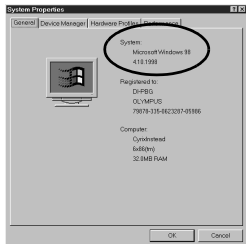

If your OS is Windows 98/98 SE, proceed to “Installing the USB driver for Windows 98” (👉 p.9).

Users running Windows Me/2000/XP 👉 p.11

Users running other OS 👉 p.31

● Mac OS (Macintosh)

Select “About This Computer” from the Apple menu on the menu bar.

A window appears with the name of the computer’s OS.

Confirm that the OS is OS 9.0-9.1 or OS X.

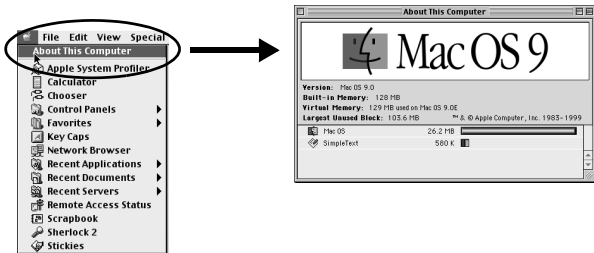

Users running Mac OS 9/X 👉 p.23

Users running other OS 👉 p.31

Windows

Using Windows 98/Me/2000/XP

Make sure that:

- Your computer is turned on and Windows is running.
- If you are running any applications, quit them all.
- You are recommended to power the camera using the optional AC adapter. If the battery power runs out while the computer is accessing the card in the camera, the camera will turn off in the middle of the operation and this could destroy image files (data). If you are using batteries, make sure that there is sufficient remaining battery power.

Installing the USB driver for Windows 98 (When using Windows 98/98 SE)	9
Connecting the camera to the computer	11
Confirming the computer recognizes the camera	14
Confirming the USB driver is installed	15
Downloading images to your computer.....	17
Disconnecting the camera from your computer	20

Installing the USB driver for Windows 98 (When using Windows 98/98 SE)

If your OS is Windows 98/98 SE, you must install the USB driver. Follow the instructions below to install the USB driver in your computer. Once it is fully installed, you do not need to repeat the procedure again.

If your OS is Windows Me/2000/XP, you do not need to install the USB driver. Proceed to “Connecting the camera to the computer” (👉 p.11).

- 1** Insert the provided software CD into your CD-ROM drive.

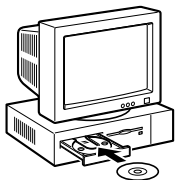

- 2** The Olympus Windows Installer should automatically launch. Click “USB Driver”.

If the USB driver is already installed in your computer, this option will not appear.

- This option will not appear if you are using Windows Me/2000/XP.

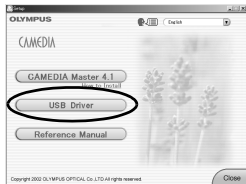

If the installer is not automatically launched, select “Run..” on the “Start” menu and then execute “(drive letter):/ Information.exe”.



The drive letter of the CD-ROM varies depending on the computer.
To identify the drive letter, double-click “My Computer” on the desktop.

- 3** Click “Continue”. The installation of the USB driver will start.



- 4** Click “OK” to restart your computer and the installation is complete.

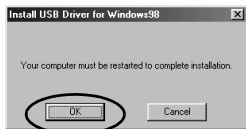

- 5** When the computer has restarted, installation is complete. If the Olympus Windows Installer screen appears, click “Close” and remove the CD-ROM from the CD-ROM drive.

Connecting the camera to the computer

Users running Windows 98/98SE need to install the USB drive before connecting the camera to your computer for the first time. (☞ p.9)

- 1** Insert the marked end of the provided USB cable into the USB port on your computer as shown below.

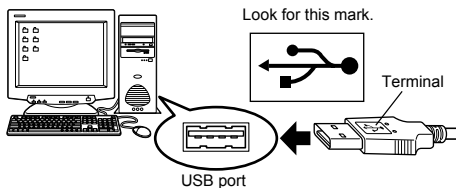

Note

The location of the USB port varies depending on the computer. For details, refer to your computer's manual.

- 2** After making sure that the camera is turned off, connect the end of the USB cable to the USB connector on the camera.

The location of the USB connector or multi connector varies depending on the camera model. Refer to the camera manual for details.

Camera with a USB connector

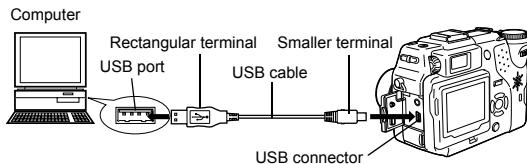

Camera with a multi connector

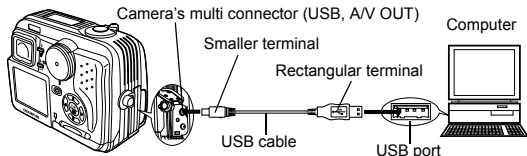

3 Turn the camera on.

- **Camera with a lens barrier**

The power turns on automatically, with the exception of some models which require you to press the  (monitor) button.

When the camera is turned on, the lamp on the right of the viewfinder lights up.

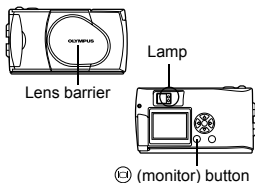

- **Camera with a  mode**

Set the mode dial to . (If the camera has a power switch as well as a mode dial, turn the power switch to ON.)

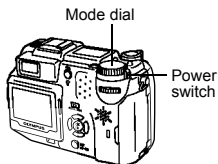
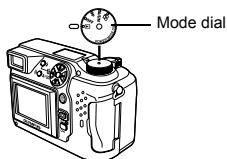

- **Camera with a  mode (Camera setup/connection mode)**

Set the mode dial to  to turn the camera on.

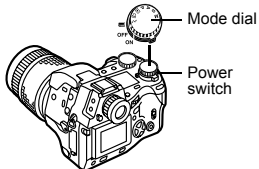

4 The computer recognizes the camera as a new device.

When you connect the camera to the computer for the first time, the computer automatically recognizes the camera. Click "OK" when the message saying that the installation is completed appears. The computer recognizes the camera as a "Removable Disk".

● Windows XP

You can download image files from the camera easily. Select "Copy pictures to folder on my computer using Microsoft Scanner and Camera Wizard", then follow the on-screen instructions. You may also select "take no action" to bypass the Microsoft Scanner and Camera Wizard. You may then use a more advanced image viewing/editing program such as Olympus CAMEDIA Master software. For detailed instructions on downloading, refer to the CAMEDIA Master software user's guide.



When the camera is connected to the computer, none of the camera buttons are functional.

Confirming the computer recognizes the camera

1 Double-click the “My Computer” icon on the desktop.

For users running Windows XP, click “My Computer” from the “Start” menu.

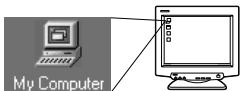

2 Make sure the “Removable Disk” icon appears in the window.

There may already be other “Removable Disk” icons for other devices, such as a removable media drive or USB SmartMedia Reader/Writer. In this case, the digital camera is recognized as another “Removable Disk”.

If you cannot find the icon, the camera and computer are not connected properly. Turn the camera off, disconnect the camera from the computer and connect again, or proceed to “Confirming the USB driver is installed” (☞ p.15) to make sure that the USB driver is fully installed.

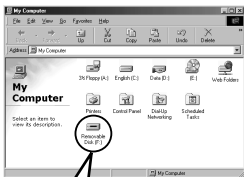

Confirming the USB driver is installed

If the computer does not recognize the camera as a Removable Disk, follow the procedure below to check whether the USB driver has been fully installed.

- 1** Open “My Computer” and double-click the “Control Panel” icon.
For users running Windows XP, open “Control Panel” from the “Start” menu.



- 2** Double-click the “System” icon.

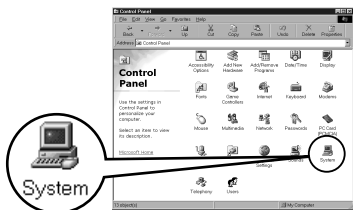

- 3** The System window will appear. Click the “Device Manager” tab.

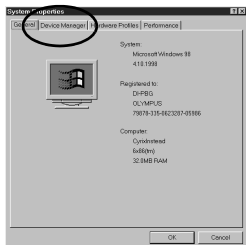

4 Confirm that “OLYMPUS Digital Camera” is in the “Universal Serial Bus Controller” category.

If you cannot find the “OLYMPUS Digital Camera”, turn the camera off, disconnect the camera from the computer and start again.

Users running Windows 98/98 SE start again from “Confirming the USB driver is installed”, and Users running Window Me/2000/XP start from “Connecting the camera to the computer”.

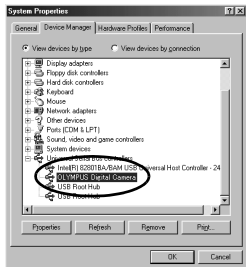

Note

If the USB driver was successfully installed, you can find the following in the “Device Manager”.

- the name of the camera you have connected listed under “Disk drives”
- “OLYMPUS Digital Camera” listed as one of the items in the “Universal Serial Bus Controller” category

Downloading images to your computer

1 Double-click the “My Computer” icon on the desktop.

For users running Windows XP, click “Control Panel” from the “Start” menu.

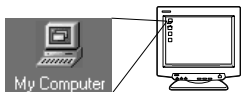

2 Double-click the “Removable Disk” icon.

A new “Removable Disk” icon appears when the camera is connected to the computer, as the digital camera is recognized as a “Removable Disk”.

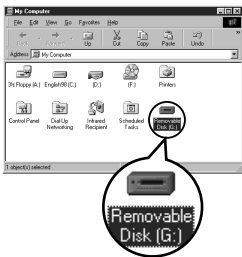

Note

If an error message appears when you double-click the icon, there may be a problem with one of the following:

- ① the camera's power source (the AC adapter is not properly connected or the battery power is low)
Make sure that the AC adapter is correctly connected or that the batteries are not running low.
- ② the card (there is no card in the camera or there is a problem with the card)
Check that you can play back pictures stored on the card on the monitor of your digital camera.

3 Double-click the “Dcim” folder.

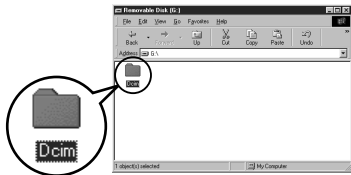

4 Double-click the “100olymp” folder.

Image files (JPEG files) with file names such as “P1010001.jpg” are displayed.

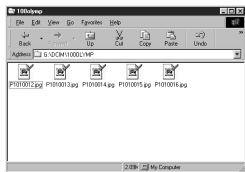

- The camera automatically assigns folder names and file names according to the following rules.

Folder name	File name
(Example) 100olymp ↓ Serial number	(Example) P1010001.jpg ↓ ↓ ↓ Month / Day / Serial number

- Serial numbers of image files run from 0001 to 9999.
- Serial numbers of folders run from 100 to 999.
- When file number 9999 is reached, a new folder is created and assigned the next number.
- Months January through September are expressed by the numbers 1 through 9, October by the letter A, November by B and December by C.

5 Double-click the “My Documents” icon on the desktop.

If you cannot find the icon on the desktop, select “Explorer” on the Start menu and double-click the “My Documents” icon.

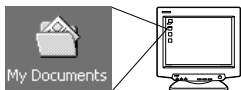

The “My Documents” window is displayed.



- 6** Drag & drop the image you want to save in the computer (in this case, P1010012.jpg) to the “My Documents” window.

The image is saved in the computer (in My Documents folder).

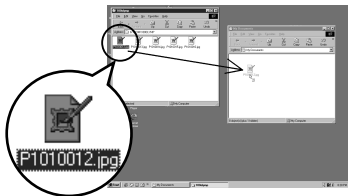

- To select all files, choose Edit > Select all.



When the image file has been downloaded to the computer, you can view images by double-clicking the image files downloaded to your computer. The files will be opened in the default image viewer of the operating system. If you want to view the image a different size or process it, you will need to open the image with software that supports JPEG or TIFF images files, such as Paint Shop Pro, Photoshop or CAMEDIA Master software.



The lamp on the right of the viewfinder or the card access lamp blinks while the image is being copied. Never open the card cover on the camera, load or remove the batteries, or connect or disconnect the AC adapter while the lamp is blinking as the image files may be destroyed.

Disconnecting the camera from your computer

If your OS is Windows Me/2000, proceed to “Windows Me/2000/XP” (p.21).

● Windows 98

- 1** Make sure that the lamp on the right of the viewfinder or the card access lamp is not blinking.

Some camera models have either a lamp on the right of the viewfinder or a card access lamp, and the location varies depending on the model. Refer to your camera's reference manual.

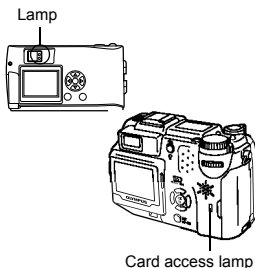

- 2** Double-click the “My Computer” icon and right-click the “Removable Disk” to display the menu.



- 3** Click “Eject” on the menu.



- 4** Make sure that the lamp on the right of the viewfinder or the card access lamp is not blinking.

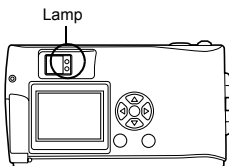

- 5** Remove the USB cable from the camera.

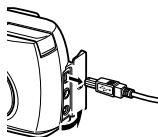

- 6** Remove the USB cable from your computer.

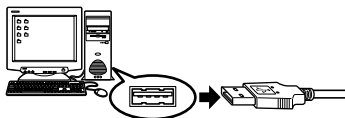

● Windows Me/2000/XP

- 1** Make sure that the lamp on the right of the viewfinder or the card access lamp is not blinking.

Some camera models have either a lamp on the right of the viewfinder or a card access lamp, and the location varies depending on the model. Refer to your camera's reference manual.

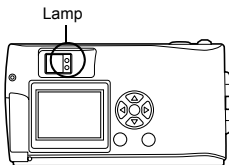

- 2** Click the  “Unplug or Eject Hardware” icon on the task bar.

The message saying that the drive has been stopped appears.

- 3** Click on the message.

The “Unplug or Eject Hardware” window appears.

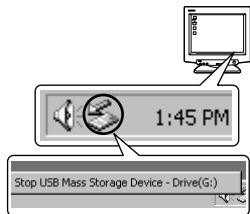

- 4** When a message appears, click “OK”.



- 5** Remove the USB cable from the camera.

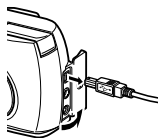

- 6** Remove the USB cable from your computer.

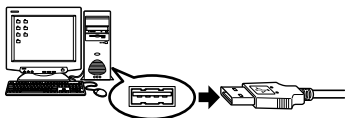

Caution

If the window returns the following message when you click “Unplug or Eject Hardware”, first make sure that no image data is being downloaded from the camera, and then remove the USB cable.

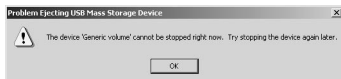

Macintosh

Using Mac OS (9/X)

Make sure that:

- Your computer is turned on and Mac OS is running.
- If you are running any applications, quit them all.
- You are recommended to power the camera using the optional AC adapter. If the battery power runs out while the computer is accessing the card in the camera, the camera will turn off in the middle of the operation and this could destroy image files (data). If you are using batteries, make sure that there is sufficient remaining battery power.

If you are running Mac OS X, the connection to the computer and downloading the image data are verified. Restrictions such as the following may occur due to the OS.

- The image file properties are not displayed correctly.
- Images in the camera cannot be opened without first downloading them. etc.

For more details, visit the Olympus web site.

Connecting the camera to the computer	24
Downloading images to your computer.....	26
Disconnecting the camera from your computer	30

Connecting the camera to the computer

- 1 Insert the marked end of the USB cable into the USB port on your computer as shown below.

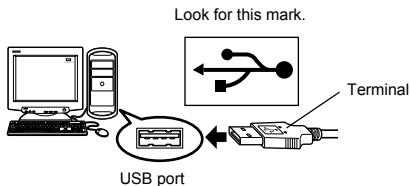

The location of the USB port varies depending on the computer. For details, refer to your computer's manual.

- 2 After making sure that the camera is turned off, connect the end of the USB cable to the USB connector on the camera.
The location of the USB connector or multi connector varies depending on the camera model. Refer to the camera manual for details.

Camera with a USB connector

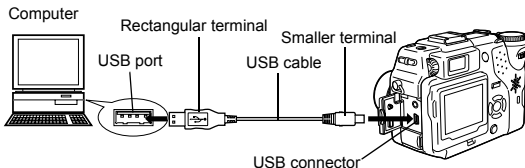

Camera with a multi connector

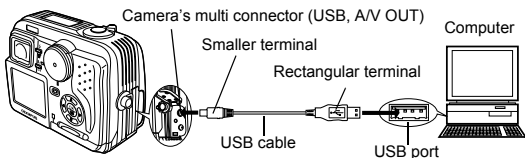

3 Turn the camera on.

● Camera with a lens barrier

The power turns on automatically, with the exception of some models which require you to press the  (monitor) button.

When the camera is turned on, the green lamp on the right of the viewfinder lights up.

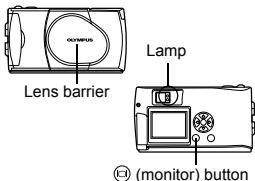

● Camera with a mode

Set the mode dial to . (If the camera has a power switch as well as a mode dial, turn the power switch to ON.)

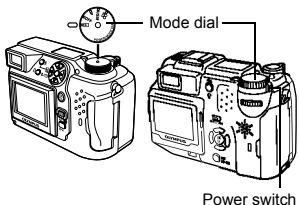

● Camera with a mode (Camera setup/connection mode)

Set the mode dial to  to turn the camera on.

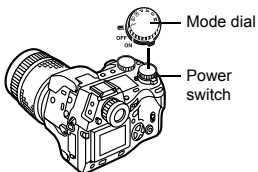

4 The computer recognizes the camera as a new device.

The computer recognizes the camera automatically and an "Untitled" icon appears on the desktop.

If you cannot find this icon, turn off the camera and connect again.



● Mac OS X

When the computer has recognized the camera, the Apple Image Capture software automatically launches.  p.29



When the camera is connected to the computer, none of the camera buttons are functional.

Downloading images to your computer

● Mac OS 9

You can download images from the camera and save them in your computer (in this case, in the Hard Disk).

- 1 Double-click the “Untitled” icon displayed on the desktop when the camera is connected to the computer.

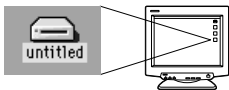

If you cannot find this icon, or if an error message appears when you double-click the icon, there may be a problem with one of the following:

- ① the camera's power source (the AC adapter is not properly connected or the battery power is low)
- ② the card (there is no card in the camera or there is a problem with the card)
Check that you can play back pictures on the monitor of your camera.
- ③ the USB cable (the camera is not properly connected to the computer by the USB cable).
- ④ Apple “File Exchange” extension is not enabled.
 - Please refer to your Apple operating system manual for instructions on how to enable this extension.

- 2 Double-click the “Dcim” folder.

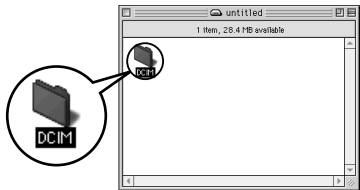

- 3 Double-click the “100OLYMP” folder.

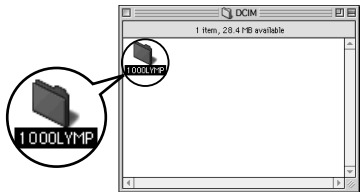
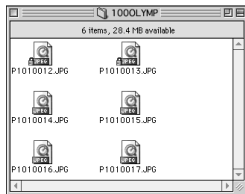
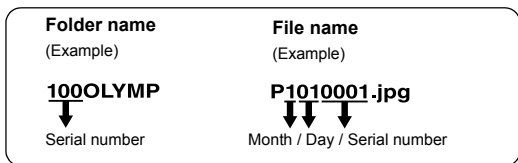

Image files (JPEG files) with file names such as “P1010001.JPG” are displayed.



- The camera automatically assigns folder names and file names according to the following rules.



- Serial numbers of image files run from 0001 to 9999.
- Serial numbers of folders run from 100 to 999.
- When file number 9999 is reached, a new folder is created and assigned the next number.
- Months January through September are expressed by the numbers 1 through 9, October by the letter A, November by B and December by C.

- 4 Double-click the “Macintosh HD” icon on the desktop.

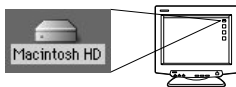

The “Hard Disk” window is displayed.

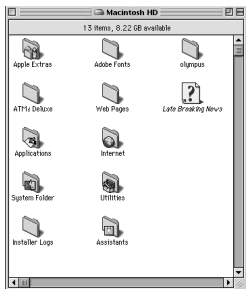

- 5** Drag & drop the image you want to save in the computer (in this case, P1010012.JPG) to the “Hard Disk” window.

The image is saved in the computer (in the Hard disk).

- To select all images, click Edit > Select all.

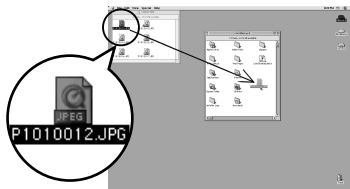

When the image file has been copied to the computer, you can view images by double-clicking the image files in the “Hard Disk” folder. The files will be opened in the default image viewer of the operating system. If you want to view the image a different size or process it, you will need to open the image with software that supports JPEG or TIFF images files, such as Paint Shop Pro, Photoshop or CAMEDIA Master software.



The lamp on the right of the viewfinder or the card access lamp blinks while the image is being copied. Never open the card cover on the camera, load or remove the batteries, or connect or disconnect the AC adapter while the lamp is blinking as the image files may be destroyed.

● Mac OS X

Malfuncions such as the following may occur due to the OS.

- If the camera is not connected correctly, a malfunction occurs in the computer.
- Date and time information of image files is not accurately displayed.
- If the card cover of the camera is opened while connecting to the computer, the “untitled” icon does not disappear from the desktop. etc.

When the computer has recognized the camera, the Apple Image Capture software dialog appears.

1 From the “Download To” menu, select a destination folder.

2 To download all images, click “Download All”.

To selectively download images, click “Download Some” and highlight the desired images.

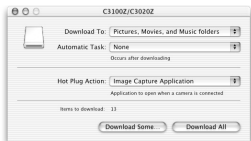

The images are transferred from the camera to your computer.



If you are operating Mac OS X and you want to download images using the same procedure as for Mac OS 9, select “File > Close” and exit the Apple Image Capture software. At this time, the camera is indicated as “unlabeled”.



Caution

If you use the Apple Image Capture software, images downloaded to your computer and transferred back to a card may not play back on the camera or may have other problems.

Disconnecting the camera from your computer

- 1** Make sure that the lamp on the right of the viewfinder or the card access lamp is not blinking.

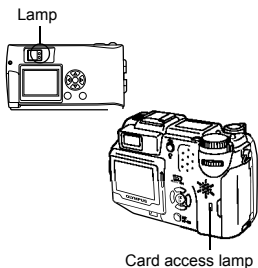

- 2** Drag the “untitled” icon on the desktop to “Trash”.

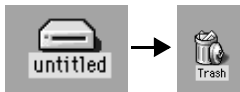

- 3** Make sure that the lamp on the right of the viewfinder or the card access lamp is not blinking.

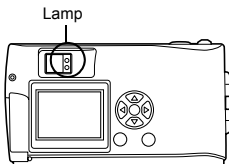

- 4** Remove the USB cable from the camera.

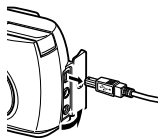

- 5** Remove the USB cable from your computer.

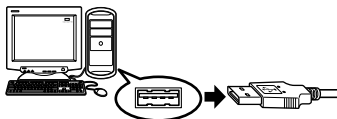

Downloading image files using other OS (For other OS users)

Users running other OS cannot connect the camera directly to a computer.

● **Windows 95** ● **Windows NT** ● **Mac OS before OS 9**

You can download images directly to your computer using an optional floppy disk adapter or PC card adapter.

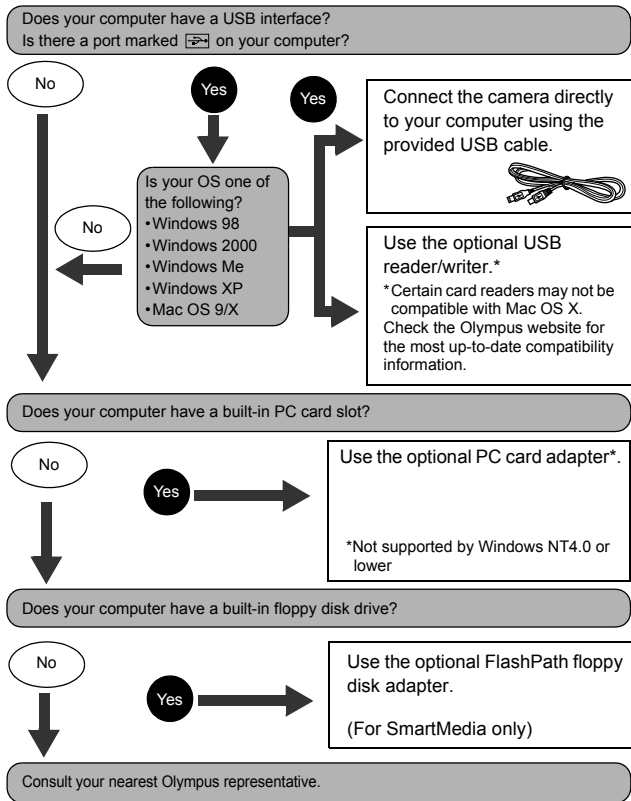

OLYMPUS

<http://www.olympus.com/>

OLYMPUS OPTICAL CO., LTD.

San-Ei Building, 22-2, Nishi Shinjuku 1-chome, Shinjuku-ku, Tokyo, Japan
Customer support (Japanese language only): Tel. 0426-42-7499 Tokyo

OLYMPUS AMERICA INC.

Two Corporate Center Drive, Melville, NY 11747-3157, U.S.A. Tel. 631-844-5000

Technical Support (USA)

24/7 online automated help: <http://support.olympusamerica.com/>

Phone customer support: Tel. 1-888-553-4448 (Toll-free)

Our phone customer support is available from 8 am to 10 pm
(Monday to Friday) ET

E-Mail: distec@olympus.com

Olympus software updates can be obtained at: <http://olympus.com/digital/>

OLYMPUS OPTICAL CO. (EUROPA) GMBH.

Premises/Goods delivery: Wendenstrasse 14-18, 20097 Hamburg, Germany
Tel. 040-23 77 33

Letters: Postfach 10 49 08, 20034 Hamburg, Germany

European Technical Customer Support:

Please visit our homepage <http://www.olympus-europa.com>

or call our TOLL FREE NUMBER : **00800 - 67 10 83 00**

for Austria, Belgium, Denmark, Finland, France, Germany, Italy, Luxembourg,
Netherlands, Norway, Portugal, Spain, Sweden, Switzerland, United Kingdom

- Please note some (mobile) phone services/provider do not permit access or request an additional prefix to +800 numbers.

For all not listed European Countries and in case that you can't get connected
to the above mentioned number please make use of the following

CHARGED NUMBERS: **+49 180 5 - 67 10 83** or **+49 40 - 237 73 899**

Our Technical Customer Support is available from 9 am to 6 pm MET (Monday to Friday)