

Photolearn

www.photolearn.co.uk

Copyright: Garry Edwards & Commercial Photography. All rights reserved
Photolearn is a subsidiary of Commercial Photography, 1A Mill Street, Bradford
BD6 3BQ. Tel: 01274 60 88 22

A brief extract from

The Photolearn Getting Started in Digital Photography tutorial

My approach to this tutorial

Well, the whole idea of this tutorial is to explain

1. How digital photography works, so that you can get the best from your camera and take better photos.
 2. How digital cameras work, so you can choose the right type of camera for your needs.
- Photography is full of jargon words. I've used plain English as far as possible, but where technical terms or jargon words are necessary, I've use them too. Each time a jargon word appears for the first time, it's printed in **bold type** and is hyperlinked and you'll find an explanation of it in the glossary at the back – just click on the term to go to the explanation.
 - Photography is a complex, technical subject. There's plenty of info available for people who want to learn about the technicalities but this tutorial is for people who want a plain-English guide to get them started.
 - If you use digital, part of the picture-making process involves computer work. This applies to film too, because negatives and transparencies can be scanned, which makes them into digital images – but this tutorial is about photography, not computer work, and I want you to learn how to produce good photos with your camera.

- Most of the photos that illustrate this tutorial are ‘as shot’ with no computer work carried out. Where any computer work *has* been carried out, as with a couple of shots where images have been combined to demonstrate a point, this is clear.
- I’ve illustrated this tutorial with photos that show ‘What happens if...’ because you’ll learn from seeing what’s gone wrong and why, you won’t learn by looking at perfect images!

This tutorial contains some basic info about the types of cameras that newcomers to photography are likely to be interested in. If you want much more detailed info about cameras then you need my ‘Cameras’ tutorial, which also includes info on flashes and other accessories.

Let's start right at the beginning. How does photography work?

Photography is the action of light on a piece of light sensitive material. In a digital camera, a [sensor](#) is used instead of the light sensitive film that is used in a [film camera](#). You can adjust the sensitivity of the sensor to light by adjusting the [ISO](#) settings. Higher ISO settings mean that shots can be taken in lower light conditions, but at the expense of image quality.

You need a [lens](#) to bring an image of the subject into the camera, control the amount of light and [focus](#) it on to the sensor. And you need a [shutter](#) to control the length of time for which the light comes into the camera.

Digital is still a new technology — Although the first digital camera (the Sony Mavica) was launched as long ago as 1981, it was 1990 before the first version of [Photoshop](#)[™] became available and the Nikon F3, fitted with a Kodak 1.3Mp digital sensor, cost more than a luxury car in 1991. The first professional digital back (the 16Mp Dicomed Bigshot) was introduced in 1992 and cost far more.

Fast forward to 2003, when Canon launched their EOS300d for under £1,000, possibly the first affordable digital aimed at the amateur market, and think of the technological progress and the price reductions that have happened since then — the ball has been rolling downhill for a while, but now it's picked up speed!

Because of the rapid progress in digital cameras, this tutorial deals with *digital photography* rather than specific digital equipment used to produce digital photographs.

The various types of digital cameras.

Basically there are 3 main types, although sometimes the dividing lines can get a bit smudged...

[Point & Shoot](#) (P&S) are the most basic type. They're aimed at people who are looking for small, compact cameras that do everything automatically. Whether they look like cameras or not, they're really miniature computers that can take basic photographs.

These cameras are ideal for people who want a small camera to carry around with them, and they're ideal if high quality is less important than convenience. Typical uses would be where only very small prints (around 6"x4") are wanted, or no prints at all, because these cameras are very useful for taking photos that are going to be sent by email or posted on sites such as Ebay, just to show what something looks like.

They're a very good idea for people who want a cheap camera and who want the convenience of digital. These cameras are small, inexpensive and simple to use but they don't allow the photographer to set the controls, and this makes them unsuitable for people who want to exercise creative control over their photography.

Next up in the quality (and cost) stakes are the point and shoot cameras designed for people who have an interest in photography and who want to exercise some level of control over the picture-taking process.

The photographer can set the shutter speed and the aperture (the amount of light allowed to pass through the lens) and sometimes other features too.

Typically these cameras will have autofocus and some can also focus manually. Some are described as 'bridge' cameras.

Basically bridge cameras are point and shoot cameras which have some of the features found on more expensive models. Creative control is very possible with this type of camera – but they are still point and shoot cameras and the image quality may disappoint you.

If you want better quality from a digital camera then you really need to take a big step upwards in terms of cost, size and complexity and get a **[DSLR](#)** .

DSLR cameras are often described as 'professional' cameras.

The word 'professional' in this context is just a marketing term and is pretty meaningless. As an example, one very well-known manufacturer produced a digital camera that they claimed produced professional quality. A few months later they discontinued it and replaced it with another, with twice the pixel count. They then said that this was their first professional digital camera. Very soon afterwards they discontinued this one too, and replaced it with a better (and cheaper) model, so you would think that this one would be called 'professional' too - but no, in the meanwhile they had brought out an even better and more expensive model and this one was described as professional, with its cheaper

brother (the replacement for their previous 'professional' camera) now described as a consumer camera!

Regardless of what their manufacturers call them these cameras generally have both fully automatic and fully manual functions. They all have interchangeable lenses and (except for the cheapest ones) they are usually sold without a lens, so that the buyer can decide on the most suitable type of lens for the type of photography they want to do.

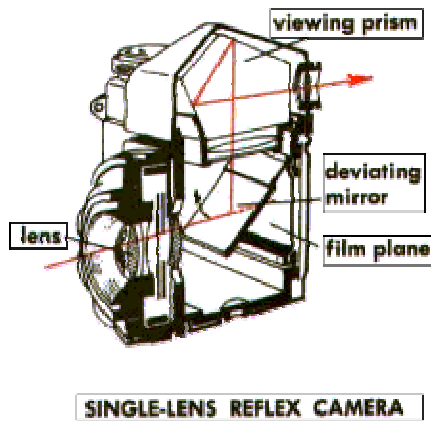

At the time of writing they have sensors that record at least 6 megapixels, but usually more. They're very similar in design and operation to 35mm film cameras, where the photographer looks through a viewfinder and sees exactly what will appear on the finished photo, because they are looking at the subject through the actual lens.

The image from the lens is deflected to the viewfinder by a mirror, which flips up out of the way when the shutter button is pressed. The image is reflected around the mirrored prism built in to the top of the camera, and you end up seeing a right way round, right way up image of what the lens actually sees.

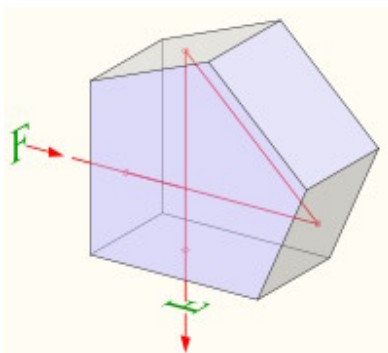

DSLR cameras also have a 'proper' camera shutter, unlike the cheaper digital cameras, which do not have mechanical shutters and where effectively the shutter is just a computer operation.

There is a 3rd category, the true professional digital cameras, but this is a very specialised (and expensive) option and so isn't included here.

Physical size of the camera

Well, this one is very much a matter of personal preference, but bear in mind that something has to give on very small cameras!

If the camera is both small and relatively simple there may not be too much of a problem, because there won't be too many buttons to press, but with more complex cameras small size can be a definite disadvantage - the buttons will be smaller, and closer together, and usually you'll find yourself having to press and hold down button A and press button B seven times to change something or other - not only is this inconvenient, especially if you have large hands, it is also almost impossible to remember!

So you may end up having to carry the instruction book around with you....

How many pixels do digital cameras need?

A **pixel** is a tiny piece of information captured by the camera and, in theory at least, the more there are of them the better the photo will be - but in practice that simply isn't true, as you'll see later, and in any case you may not need a lot of pixels - it all depends on your personal quality needs and the use to which you're going to put the pictures.

Let's assume, for example, the following uses:-

Post 6"x4" pictures on Ebay, to help sell your auction items. You need a picture of around 6"x4" at 72 **ppi** - 432 x 288 pixels = 124416, or 0.12Mp

Email 9"x6" pics to your friends. You need a picture of 648 x 432 at 72 ppi = 279936, or 0.28Mp

Get your family snaps printed by Jessops (or similar) size 6"x4" 1200x800 (resolution 200 ppi) = 1030400, or 1.03Mp

Get your family snaps printed by Jessops (or similar) size 9"x6" 1800x1200 (resolution 200 ppi) = 2160000, or 2.16Mp

Get your photos printed in a book, magazine or brochure, size 9"x6" 2700x1800 (resolution 300 ppi) = 4860000, or 4.86Mp

Get your photos printed as a double page spread in a top quality A4 magazine 7016x9921 pixels (resolution 600 ppi) , or = 69Mp

Mp = Megapixel (millions of pixels).

O.K., this means that any digital camera will be fine for sending pictures by email or posting on the web. And almost any digital camera can produce prints of your family snapshots. You don't need a 5 Mp or larger camera unless you want your photos printed to professional standards, or as very large prints.

And here's a very important truth that the manufacturers and salesmen may not get around to telling you - the amount of detail captured by your digital camera will depend on the number of pixels *actually recorded by its sensor*. You can 'add' more pixels later, on your computer (a process known as interpolation) but this only makes the file larger, *it does not and cannot add information that wasn't there in the first place!*

Now, there are some camera manufacturers who have built software into their cameras that does this interpolation automatically. Some of them add 50% and some add 100% or even 400%. What you, as the customer, end up with is (for example) a camera that *claims* to produce 6Mp but which in reality only produces 3, or a camera that claims 12Mp but which really only produces 3. Various terms are used in the sales literature to describe these 'increases', such as interpolation, image processing, algorithm, up-sampling, post-processing - but somewhere, perhaps honestly stated or perhaps hidden away in the small print, should be the *actual* number of pixels.

Some people believe that interpolation produces better quality but they're wrong. Interpolation only allows larger prints to be made with the same density of pixels, and it can't add detail that isn't there. And anyway, if you need to increase the size of the file it's much better to do it on your computer than to rely on the tiny computer contained in a digital camera.

Double the pixels, double the resolution – right?

Wrong. If you double the number of pixels you will only increase the resolution by 50%. Because of this, it's difficult to see any increase in resolution between a camera with, say, 6 MP and one with 8MP. The real difference is only 16.5%.

Is the actual number of pixels what it's all about then?

No, because it doesn't necessarily follow that the cameras with more pixels produce higher quality than those with less. One factor that is more important than the number of pixels is the size of the sensor that records them.

The reasons for this are fairly complex but if you're not too concerned with the physics, all you need to know is that when the manufacturers reduce the physical size (and production cost) of the camera by 'shrinking' the size of the

sensor then they're reducing the quality too. And most people simply don't realise just how small these sensors are in the cheaper digital cameras. Some of them are only 4 x 3mm - and that means that the pixels themselves are tiny and cannot properly capture the light from the lens. And even then, the problems aren't over because the picture has to be enlarged so much to get a decent size print - an enlargement of over 50 times the sensor size, just to get a 10"x8" print - and you know what happens to quality when you enlarge a photo....

For example, if you take 'full frame' (36 x 24mm) digital image and enlarge it to 8"x12", this is an enlargement of 8 times. The enlargement will magnify any camera shake and poor focus x8 too. It will also enlarge the noise by x8. But only the most expensive digital cameras use a full-frame sensor so there has to be a substantial loss of quality if you enlarge the picture too much. My advice to you is to go for a camera that has a relatively large sensor, this is far more important than the number of pixels.

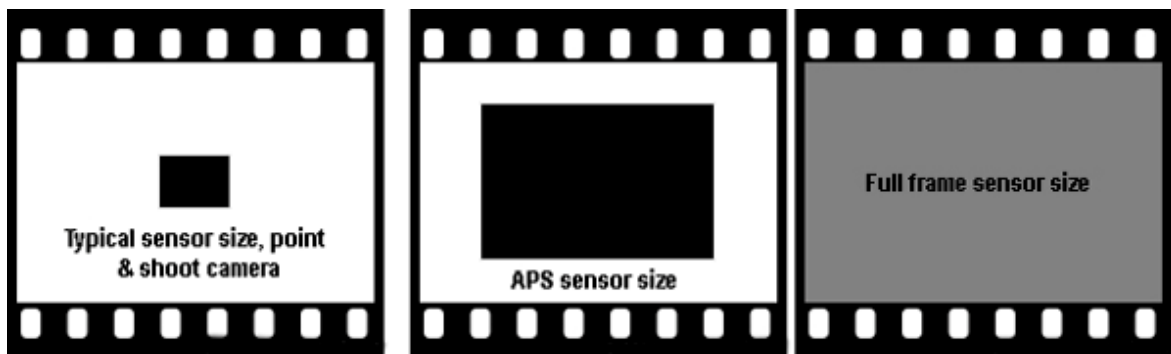

Take the graphic above left – this is the typical size of the sensor in a point and shoot camera. In terms of area it's only about 20 sq mm. The graphic above centre is the typical size of the sensor in most DSLR cameras. In terms of area it's about 330 sq mm, a substantial increase on the typical sensor fitted to a point and shoot camera. The background area in these graphics represents the size of the chip in a 'full frame' digital camera and it amounts to 864 sq mm. Given that bigger sensors produce better image quality and that they cost much more to produce, you have to decide whether you want the convenience of a small point and shoot camera or the image quality of a larger one.

And don't be deceived by adverts that claim their cameras have (for example) 1 1/8th " or 3/4" sensors - this term does **not** mean what you expect it to mean, the term bears little relation to the real size.

The type designation harks back to a set of standard sizes given to TV camera tubes in the 1950's. These sizes were typically 1/2", 2/3" etc. The size

designation does not define the diagonal of the sensor area but rather the outer diameter of the long glass envelope of the tube. Engineers soon discovered that for various reasons the usable area of this imaging plane was approximately two thirds of the designated size. This designation has clearly stuck (although it has the potential to mislead and should have been thrown out long ago).

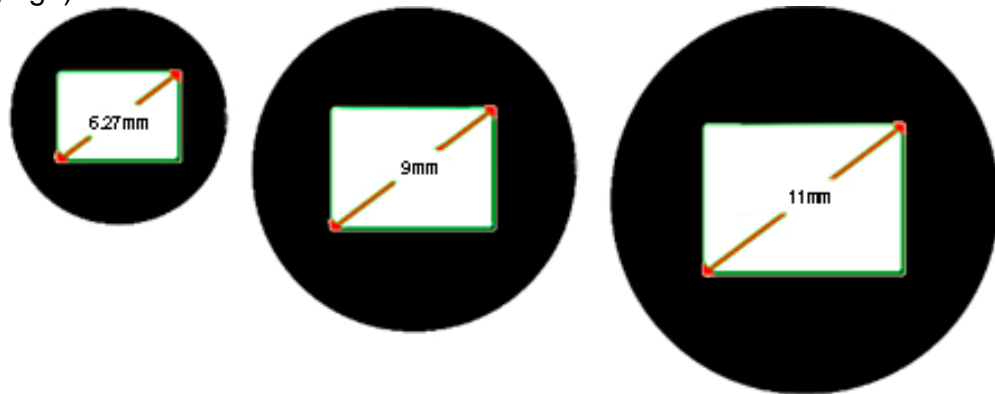

Chip sizes : 5.37mm x 4.04mm
Designated sizes: 12.7"

7.2mm x 5.35mm
1 1/8"

8.9mm x 6.6mm
23"

What you need to know is the actual size of the sensor, in mm. Unfortunately the actual physical size of the sensor is something that the manufacturers tend not to shout about, unless of course their camera has a decent-sized sensor.

Logic tells us that it must be better to have a camera that has 8 million pixels than one that has only 3 million - and so it is, but only if the pixels in the 8MP camera are the same size and the same distance apart from each other in both cameras. The reality of course is that, because the sensor is the most expensive part of the camera, it is made as small as possible and the pixels themselves are miniaturised. Because of this the overall quality of an 8 MP camera is likely to be *worse* than that of a 3 MP camera with the same size sensor - the pixel count is just marketing hype!

Most of the DSLR cameras have **'APS'** size sensors. APS was the ill-fated film size 'standard' introduced a few years ago by most of the camera manufacturers. The public liked it far less than the manufacturers and few were sold, so not everyone knows what 'APS' means.

APS means (about) 22 x 15mm, or about 330 sq mm area of digital chip and nearly all DSLR manufacturers have adopted it, or something very close to it. The actual dimensions vary between manufacturers and models. It can

produce pretty good quality and is a reasonable compromise between quality and production cost.

Olympus (and others) have adopted the [4/3rds format](#), which is a different shape to the 'standard' 3:2 ratio commonly used. It makes a lot of sense to produce a camera with this shape of sensor, partly for technical reasons and partly because 4:3 is much closer to 'standard' print sizes than the 3:2 size ratio of APS or full frame sensors.

But the sensor is smaller than APS. Here are the 'crop factor' figures for the various formats - crop factor means the effect, in terms of magnification, of using a given lens.

4/3rds: 100mm lens = 200mm on a [full frame](#) camera

APS: 100mm lens = 150-160mm (approx) on a full frame camera

And Canon and Kodak both introduced DSLR cameras with 'full frame' sensors, 36mm x 24mm.) The Kodak (DCS14N & DCS14C) were basically studio cameras capable of very high image quality under controlled conditions but they didn't sell too well and were discontinued in 2005.



Canon make their top end cameras with full frame sensors and Nikon announced their first full frame camera, the D3, in August 2007.

Photolearn

www.photolearn.co.uk

Copyright: Garry Edwards & Commercial Photography. All rights reserved
Photolearn is a subsidiary of Commercial Photography, 1A Mill Street, Bradford
BD6 3BQ. Tel: 01274 60 88 22